

INSTRUCTION MANUAL

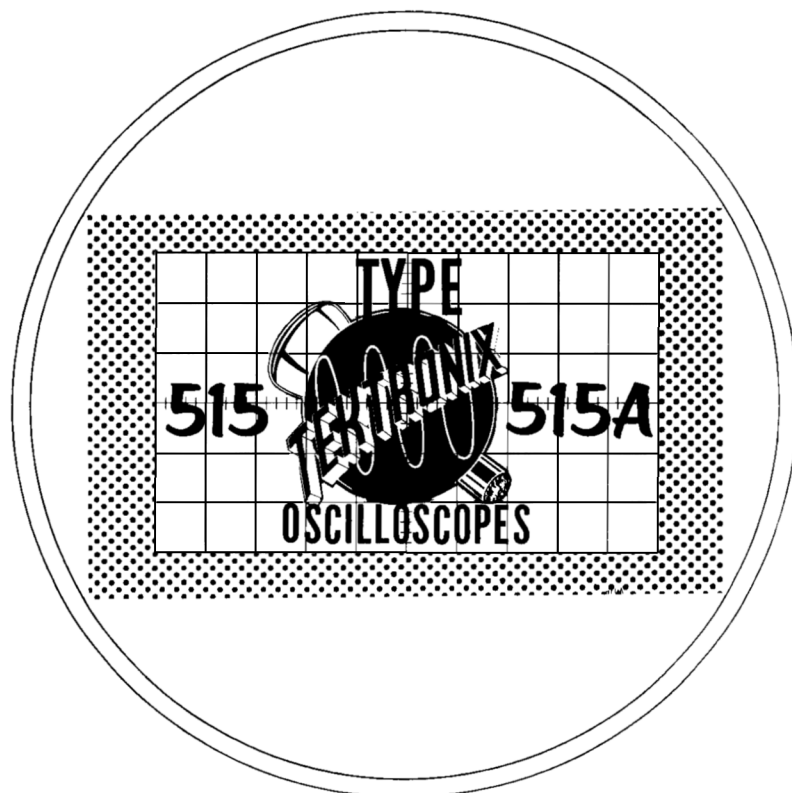



WARRANTY

All Tektronix instruments are warranted against defective materials and workmanship for one year. Tektronix transformers, manufactured in our own plant, are warranted for the life of the instrument.

Any questions with respect to the warranty mentioned above should be taken up with your Tektronix Field Engineer.

Tektronix repair and replacement-part service is geared directly to the field, therefore all requests for repairs and replacement parts should be directed to the Tektronix Field Office or Representative in your area. This procedure will assure you the fastest possible service. Please include the instrument Type and Serial number with all requests for parts or service.

Specifications and price change privileges reserved.

Copyright © 1960 by Tektronix, Inc., Beaverton, Oregon. Printed in the United States of America. All rights reserved. Contents of this publication may not be reproduced in any form without permission of the copyright owner.



CONTENTS

Warranty

Section 1 Specifications

Section 2 Operating Instructions

Section 3 Circuit Description

Section 4 Maintenance

Section 5 Recalibration Procedure

Section 6 Parts List and Schematic Diagrams

Section 7 Accessories

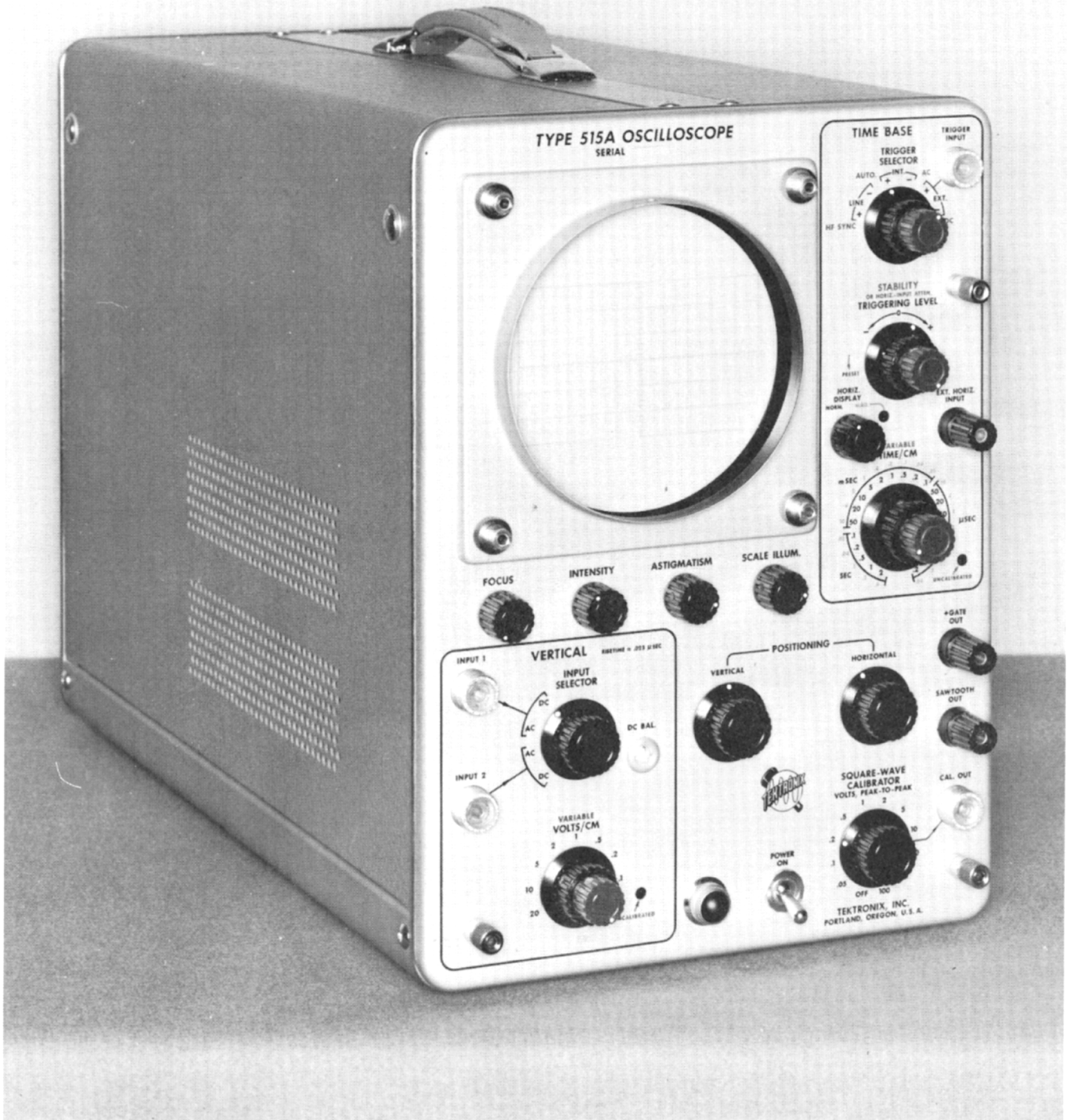

Type 515/515A

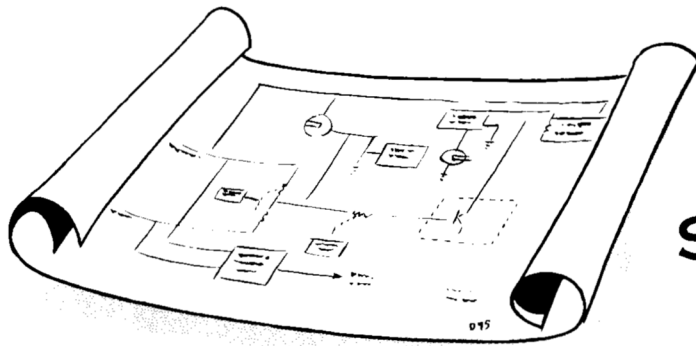

SPECIFICATIONS

The Type 515/515A Oscilloscope is a compact, portable, general purpose oscilloscope. The dc-coupled amplifier and wide range of sweep rates, combined with reduced size, make the Type 515/515A a versatile field or laboratory instrument.

Vertical-Deflection System

Deflection Factor-.05 volt/cm ac or dc. (.1 volt/cm ac or dc S/N 101-1000)

Frequency Response-dc to 15 mc, 2 cycles to 15 mc ac. (Down not more than 3 db at above limits.)

Rise Time-.023 microseconds.

Linear Deflection-6 cm.

Step Attenuator-Nine positions, calibrated, from .05 v/cm (.1 v/cm S/N 101-1000) to 20 v/cm, (50 v/cm S/N 101-1000) accurate within 3% when set on any one step.

Maximum Allowable Combined DC and Peak AC Voltage Input-600 v.

Input Impedance-1 megohm, 30 $\mu\mu\text{f}$; with P410 probe-10 megohm, 10.5 $\mu\mu\text{f}$. With P6000 probe, 10 megohm, 11.5 $\mu\mu\text{f}$.

Horizontal-Deflection System

Time Base Range

Twenty-two calibrated time bases from .2 $\mu\text{sec/cm}$ to 2 sec/cm.

Accuracy-3 per cent.

Continuously variable, uncalibrated between ranges and to 6 sec/cm.

Magnifier

Expands sweep 5 times to right and left of screen center. Extends fastest sweep rate to .04 $\mu\text{sec/cm}$.

Accuracy-5 per cent.

Unblanking-DC coupled.

Trigger Requirements

Internal-2 mm of deflection.

External-.2 volts to 20 volts.

Frequency Range-dc to 15 mc.

Horizontal Input

Deflection Factor-1.4 v/cm.

Frequency Response-DC to 500 kc, 3 db down.

Other Characteristics

Cathode-Ray Tube

Type T55P2.

P1, P7, and P11 phosphors optional.

Accelerating Potential-4,000 volts.

Deflection Factor at Plates

Vertical-5 v/cm.

Horizontal-20 v/cm.

Voltage Calibrator

Eleven fixed voltages from .05 volts to 100 volts, peak to peak.

Accuracy-3 per cent.

Waveform-square wave at about 1 kc.

Output Waveforms Available

Positive gate of same duration as sweep, approx. 20 volts. Positive going sweep sawtooth, 150 volts.

Power Supply

Electronic Regulation.

Power Requirements-105 to 125, or 210 to 250 v, 50-60 cycles, 275 watts.

Mechanical Specifications

Ventilation-Filtered, forced-air ventilation.

Finish - Photo-etched, anodized panel, blue wrinkle, perforated cabinet.

Dimensions-9 3/4" wide, 13 1/2" high, 21 1/2" deep.

Weight-40 pounds.

Accessories Included

1- P6017 probe.

1-A510 Binding Post Adapter.

1-F510-5 green filter.

1-Instruction manual.

EXPORT POWER TRANSFORMER

Transformer Primary

The instrument for which this manual was prepared is equipped with a special transformer. The transformer has eight primary terminals making possible six different input connections. The six primary connections are shown in Fig. 1.

POWER TRANSFORMER HAS TWO EXTRA WINDINGS PERMITTING NOMINAL PRIMARY VOLTAGES OF 110, 117, 124, 220, 234, OR 248 V, 50 OR 60~ OPERATION.

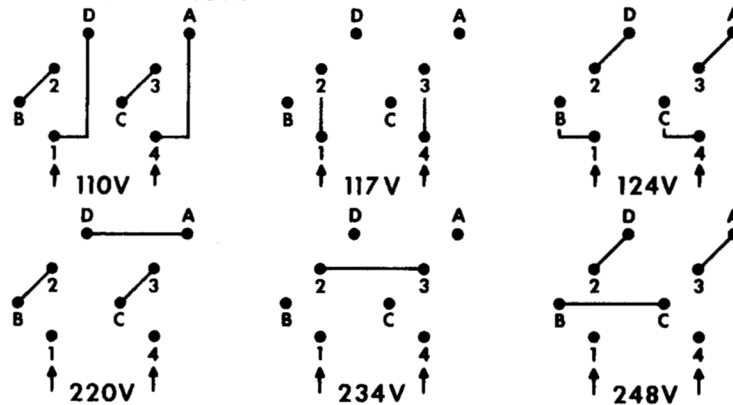

Fig.1. The power transformer has two extra windings permitting nominal primary voltages of 110, 117, 124, 220, 234, 248 volts, 50 or 60 cycle operation.

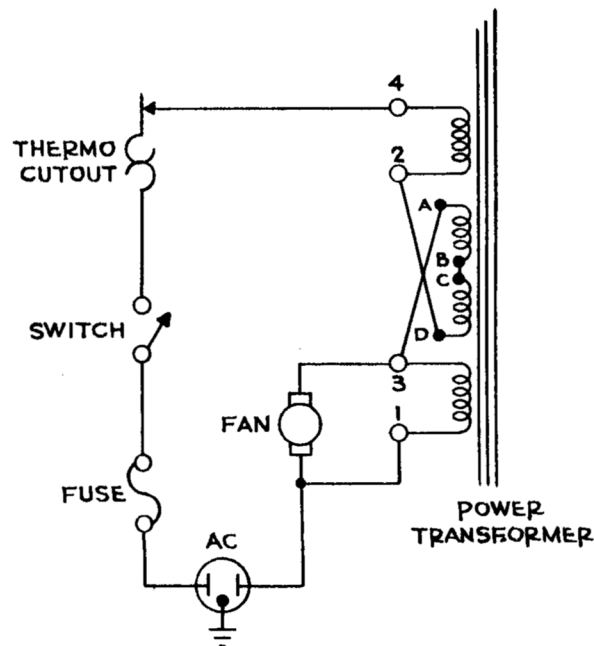
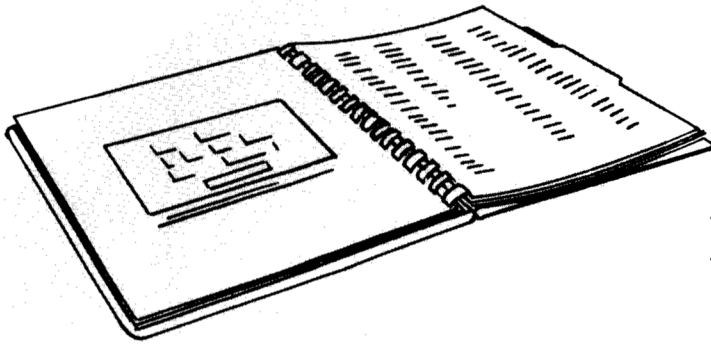

Fig. 2. When connecting the power transformer for operation with a supply voltage of 200 volts or more, be sure that the fan is connected between pins 1 and 3 of the primary. This is to insure that the fan is supplied with no more than 125 volts. Fig. 2 shows a typical high-voltage fan connection, using as an example the wiring for a 248 volt supply.

SECTION 2



OPERATING INSTRUCTIONS

General Information

The Type 515/515A Oscilloscopes are extremely versatile instruments, adaptable to a great number of applications. However, to make use of the full potentialities of the instrument, it is necessary that you understand completely the operation of each control. This portion of the Operators Manual is intended to provide you with the basic information that you require. If you are familiar with other Tektronix oscilloscopes, you should have very little difficulty in understanding the operation of the 515/515A, since the function of many of the controls is the same as the function of corresponding controls in other Tektronix instruments.

Cooling

A fan maintains safe operating temperature in the Type 515/515A Oscilloscope by circulating air through a filter and over the rectifiers and other components. The instrument must therefore be placed so the air intake is not blocked. The air filter must be kept clean to permit adequate air circulation. If the interior temperature does rise too high for some reason, a thermal cutout switch will disconnect the power and keep it disconnected until the temperature drops to a safe value.

Power Requirements

The regulated power supplies in the Type 515/515A will operate with line voltages from 105 to 125 volts or from 210 to 250 volts. For maximum dependability and long tube life the voltage should be near the center of this range.

Voltages outside of these limits may cause hum or jitter on the trace. Be sure the line voltage is correct if indications such as these are present.

Unless tagged otherwise, this oscilloscope is connected at the factory for 117-volt operation. For 234-volt operation, refer to the Maintenance section of this manual for proper transformer connections.

FIRST-TIME OPERATION

Control Settings

The following procedure will help you get a trace on the screen and become familiar with some of the controls.

Connect the line cord to a source of 117-volt 50 to 60 cycle power, and set the front-panel controls as follows:

FOCUS	Centered
INTENSITY	Counterclockwise (CCW)
ASTIGMATISM	Centered
POWER	ON
INPUT SELECTOR	INPUT 1, DC
VOLTS/CM (black knob)	5
TRIGGER SELECTOR	
black knob	+INT
red knob	AUTO
TRIGGERING LEVEL	Counterclockwise
STABILITY (red knob)	PRESET (CCW S/N 101-1000)
HORIZ. DISPLAY	NORM.

TIME/CM	.5 MILLISEC
VERTICAL POSITIONING	Center
HORIZONTAL POSITIONING	Center
CALIBRATOR	10

Connect a lead from the CAL. OUT connector to the INPUT 1 connector. If the tubes have had time to warm up, turn the INTENSITY control clockwise until a trace is visible on the screen. Adjust the FOCUS, ASTIGMATISM and INTENSITY controls to produce a sharp trace of comfortable brightness.

The two POSITIONING controls will move the trace vertically and horizontally as necessary to position the display where you want it on the crt screen.

Triggering Modes

If you have not had previous experience with the type of trigger controls used on this oscilloscope, the calibrator waveform is a good one to practice with. A few minutes spent on trying the triggering modes described below will be time well spent in terms of future operating convenience.

Auto

The triggering method used in the preceding example is the AUTO. (automatic) mode of operation. It is the simplest mode of triggering. There are no front-panel controls to be adjusted when using this mode. If the signal is removed from the input connector, the sweep will continue, but at a reduced repetition rate. This provides a visual indication that the signal has been removed and the sweep and triggering circuits are operating.

FUNCTIONS OF CONTROLS AND CONNECTORS

CRT Controls

FOCUS	Control to adjust the beam for maximum sharpness of the trace.
INTENSITY	Control to vary the brightness of the trace.

AC

Now try the AC mode of triggering. Turn the red TRIGGER SELECTOR knob to AC. Advance the TRIGGERING LEVEL control clockwise until you get a stable trace. There may be a considerable range over which you get a stable trace. The start of the trace will move up and down the edge of the square wave over this range. Notice that the trace starts on the up-going part of the calibrator square wave.

Now turn the black TRIGGER SELECTOR switch to the -INT position and readjust the TRIGGERING LEVEL control to get a stable trace again. Notice now that the trace starts on the down-going portion of the square wave and that the position of the start can again be changed somewhat with the level control.

DC

Turn the red TRIGGER SELECTOR knob to DC. If necessary adjust the TRIGGERING LEVEL control for stable triggering. Move the trace vertically on the screen with the VERTICAL POSITIONING control and note that triggering occurs at a vertical level on the screen selected by the LEVEL control, and that the triggering point changes relative to the waveform as the waveform is positioned vertically. This effect will be more noticeable if you look at a low-frequency sine wave.

H F Sync

The H F SYNC position of the TRIGGERING SELECTOR switch is primarily for signals having a repetition rate in excess of five megacycles. In this position the time base will trigger poorly, if at all, on the calibrator waveform. To stabilize the display of a high-frequency signal, simply advance the STABILITY control clockwise until a stable trace is obtained. The LEVEL control is not used in the H F SYNC mode.

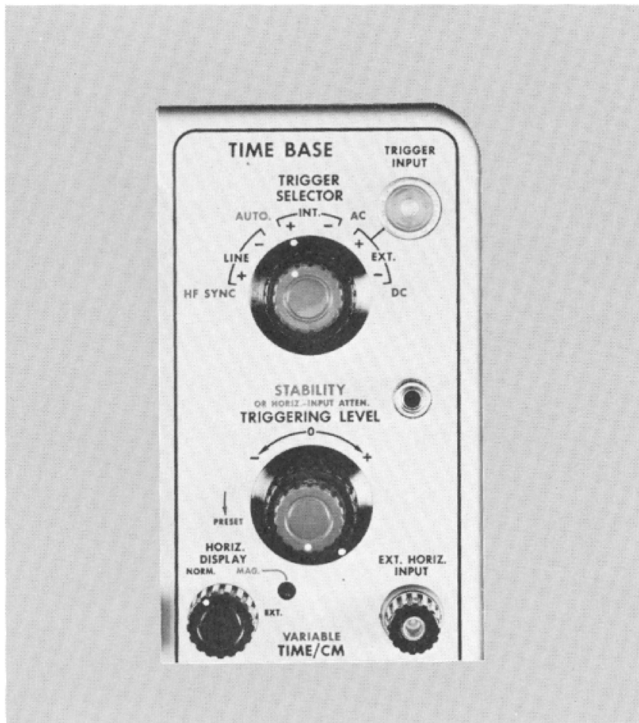

Fig. 2-1. Sweep controls in typical position for AUTO mode of triggering. This mode is the most convenient triggering method over the frequency range from 60 cps to 2 mc.

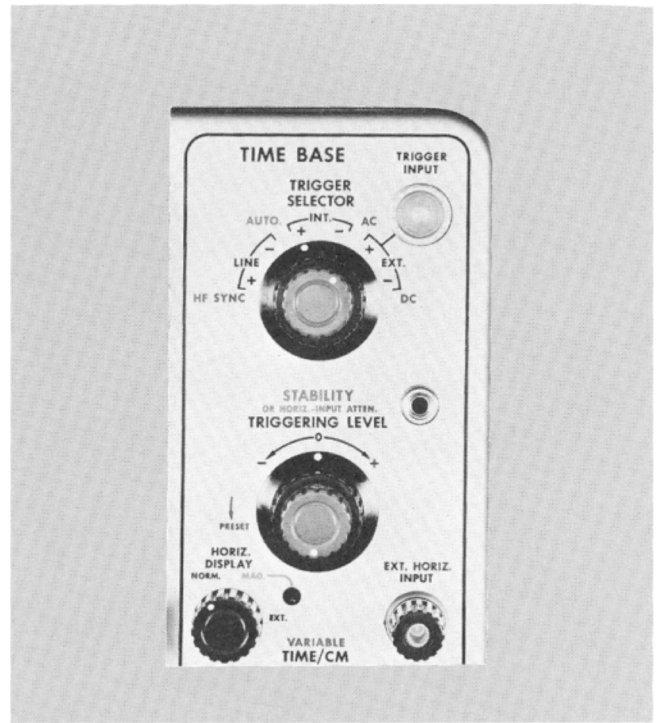

Fig. 2-2. Sweep controls in typical position for AC mode of triggering. This mode is useful for general-purpose triggering over the range from 60 cps to 5 mc.

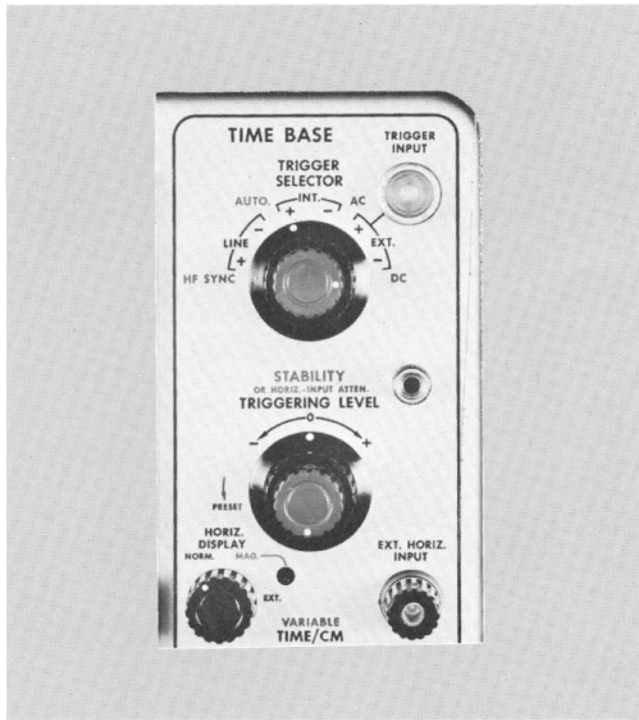

Fig. 2-3. Sweep controls in typical position for DC mode of triggering. This mode is particularly useful for the frequency range below 60 cps.

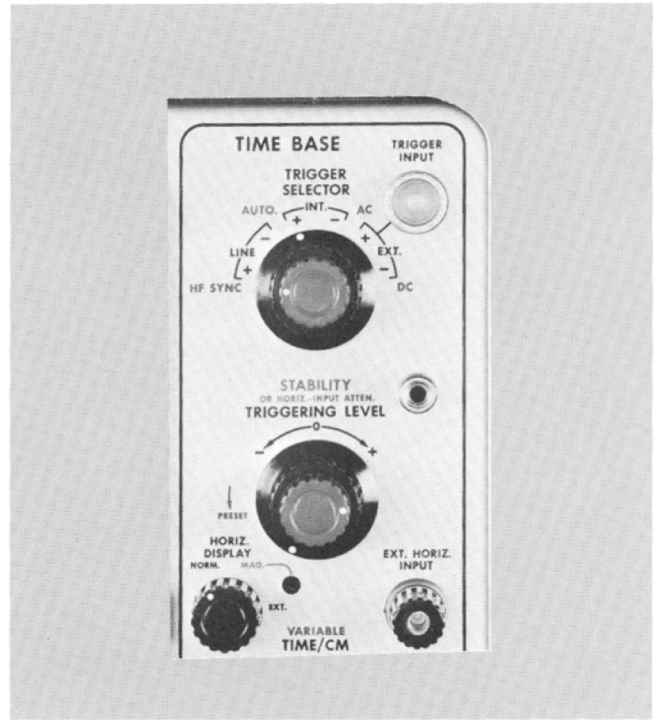

Fig. 2-4. Sweep controls in typical position for HF SYNC mode of triggering. This mode is most effective about 5 mc.

ASTIGMATISM	Control used in conjunction with the FOCUS control to adjust the beam for maximum sharpness of the trace.
SCALE ILLUM.	Control to vary the brightness of the graticule illumination.
VERTICAL POSITIONING	Control to position the trace vertically.
HORIZONTAL POSITIONING	Control to position the trace horizontally.
Time-Base Generator	
TRIGGER SELECTOR (red knob)	Four-position switch to select four kinds of triggering: H F SYNC, AUTO, AC and DC.
TRIGGER SELECTOR (black knob)	Six-position switch to select the source and polarity of the triggering signal.
TRIGGER INPUT	Coax connector to triggering circuits.
STABILITY	Control to adjust time-base circuits for triggered or recurrent operation. This control has a PRESET position suitable for most triggering applications (S/N 1001-up). This control also functions as an attenuator for external signals connected to the EXT. HORIZ. INPUT binding post.
TRIGGERING LEVEL	Control to select the point on the triggering waveform where the time base begins.
HORIZ. DISPLAY	Three-position switch to increase the sweep rate five times in the MAG. position and to connect the horizontal amplifier to the EXT. HORIZ. INPUT binding post in the EXT. position. When this control is in the MAG. position, the MAG. light indicates that the sweep rate has been increased five times.
EXT. HORIZ. INPUT	Binding post to apply an external signal to the horizontal amplifier.
TIME/CM	Twenty-two-position switch to select calibrated sweep rates from 2 sec/cm to .2 μ sec/cm.
VARIABLE (red knob)	Continuously variable control to vary the sweep rate between ranges and to 5 sec/cm. When this control is away from the clockwise stop the UNCALIBRATED light indicates that the time base is not calibrated.
Vertical Amplifier	
INPUT 1 INPUT 2	Separate signal inputs to the vertical amplifier by way of the INPUT SELECTOR switch.
INPUT SELECTOR	Four-position switch to select either input connector and insert or remove a dc blocking capacitor from the input circuits.
DC BAL.	Screwdriver control to balance the amplifier circuits so that there is no shift in the trace position as the VARIABLE control is rotated.

VOLTS/CM	Nine-position switch to select the desired deflection sensitivity.
VARIABLE	Continuously variable control to vary the sensitivity between ranges and to 50 volts/cm. When this control is away from the clockwise stop the UNCALIBRATED light indicates that the amplifier is not calibrated.

Auxiliary Functions

+GATE	Binding post to supply a positive pulse for the duration of the time base.
SAWTOOTH OUT	Binding post to supply a positive-going sawtooth, synchronized with the internal time base.
SQUARE-WAVE CALIBRATOR	Twelve-position switch to select one of eleven taps on a precision voltage divider in the calibrator circuit and to turn the calibrator off.
CAL. OUT	Coax connector from the calibrator.
POWER	On-off switch in the lead to the power transformer and fan.

Rear Panel

CRT CATHODE	Binding post to the crt cathode for the application of intensity modulation.
-------------	--

TRIGGERING INSTRUCTIONS

General

The function of the trigger circuit is to derive from the incoming waveform a sharp pulse of suitable amplitude to trigger the time-base generator. One such pulse occurs for each cycle of the incoming waveform. This pulse is independent of the incoming waveform in shape and amplitude.

The time-base generator develops the sawtooth waveform necessary to provide a linear time base. If the STABILITY control is set for triggered operation, the time base circuits wait until a trigger pulse is received, at which time one sawtooth waveform is produced. After the sawtooth waveform is completed the time base circuits wait for the next trigger pulse and the process is repeated.

The following paragraphs describe the function of the controls which affect this operation. Later paragraphs describe specific triggering procedures.

Triggering Controls

Triggering Level

In the Type 515/515A the TRIGGERING LEVEL control determines the point on the triggering waveform at which triggering will occur. The

TRIGGERING LEVEL control is not a trigger amplitude or gain control if you are accustomed to this type of circuit. Instead, it is an amplitude or voltage discriminator. If the waveform you are observing is centered on the screen and the TRIGGERING LEVEL control is set near 0 the sweep will start as the waveform passes through the center line on the screen. As the LEVEL control is turned clockwise, the triggering point will move above the center line on the screen, and, as it is turned counter-clockwise the triggering point will move below the center line. If the LEVEL control is set for a voltage greater than that of the waveform being observed the sweep will stop. Thus, if the waveform is of low amplitude the LEVEL control should be set near 0 (or near the dc level with DC triggering). The LEVEL control is used only in the AC and DC positions of the TRIGGER SELECTOR switch.

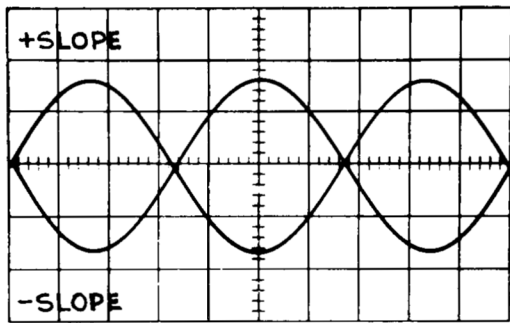

Fig. 2-5. Photograph showing the effect of the + and - positions of the black TRIGGER SELECTOR knob.

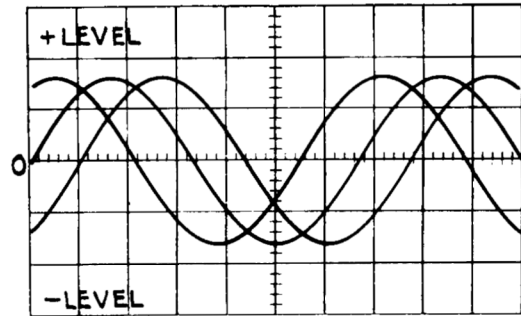

Fig. 2-6. Photograph showing the phase-shifting effect of the TRIGGERING LEVEL control. All waveforms were obtained with the TRIGGER SELECTOR set at +INT.

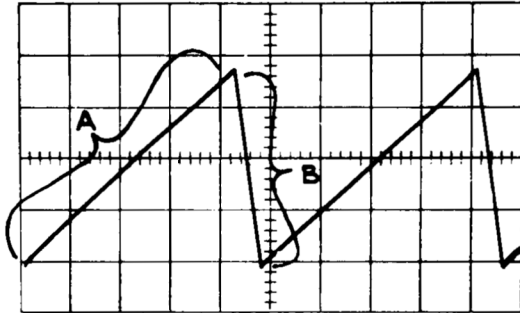

Fig. 2-7. To trigger along slope A set the black TRIGGER SELECTOR knob to +. Use the positions marked - to trigger along slope B. For maximum trace stability, trigger on the fastest rising or falling portion of a waveform.

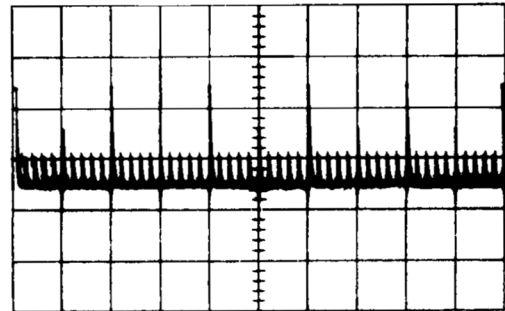

Fig. 2-8. Photograph showing an application of the level selection ability of the TRIGGERING LEVEL control. By setting the LEVEL control to the + side of the 0 mark, the trigger circuits can be made to reject all of the waveform except the highest peaks.

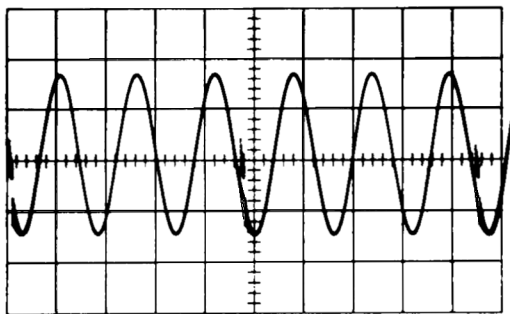

Fig. 2-9. Photograph showing a waveform where external triggering may be needed to examine a small discontinuity in a larger waveform. Usually a triggering waveform can be obtained which is synchronized with the discontinuity.

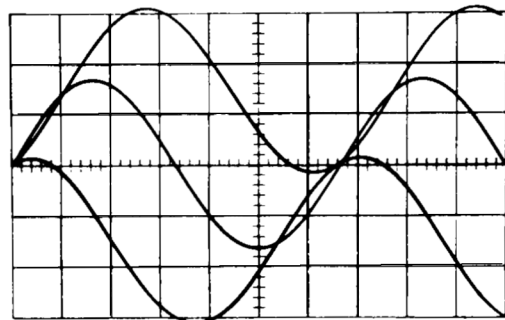

Fig. 2-10. A triple-exposure photograph of a waveform showing the effect of positioning on the triggering point when using the DC triggering mode. The TRIGGER SELECTOR controls are set at +INT, DC and the TRIGGERING LEVEL control is at 0.

Trigger Slope

The black TRIGGER SELECTOR knob selects the trigger source and determines whether the sweep will start as the waveform is going positive or negative. The + positions of this switch cause triggering to occur during the rising portion of the waveform. The - positions cause triggering to occur during the falling portion of the waveform. The trigger slope feature is not used in the H F SYNC mode.

Triggering Mode

The red TRIGGER SELECTOR knob selects the kind, or mode, of triggering used. The DC position will permit triggering on all signals from dc to about five megacycles. It is especially useful for signals below 60 cycles where the sensitivity of AC triggering begins to fall off.

In the AC position, the switch inserts a capacitor in the trigger circuits to make the trigger settings independent of the vertical position of the trace. This mode is slightly more sensitive than the DC mode.

The AUTO position arranges the circuits for an automatic synchronizing action rather than a strict triggering action. In this position the trigger-shaper multivibrator free-runs at a repetition rate of about 50 cycles. The multivibrator will lock in and run synchronously with trigger signals from 60 cycles to about 2 megacycles. If the trigger signal is lost the sweep will not stop but will continue at a reduced repetition rate without synchronization.

In the H F SYNC position the trigger-shaper circuits are bypassed and the triggering waveform is used to synchronize the time base circuits directly. The time-base generator must be free-running for this type of operation. It free-runs at advanced settings of the STABILITY control. This mode of operation is primarily useful for signals in excess of two megacycles.

Stability

The STABILITY control adjusts the bias level on a multivibrator in the time-base generator near the level at which the sweep will free-run. Three principal settings of the STABILITY control are used; the first setting

is with the control advanced to the right, past the point where the generator free-runs; second, retarded to the left just past the point where free-running ceases; and third, retarded all the way left to make the generator inoperative. The second setting is duplicated by an internal circuit when the STABILITY control is rotated to the PRESET position.

When the time-base generator free-runs, the sawtooth waveforms are produced at a repetition rate determined by the generator circuit itself. The STABILITY control varies this repetition rate slightly. In the second, or triggered, position of the STABILITY control the time-base generator does not run until a trigger pulse is received at which time one sawtooth waveform is produced and the generator waits for the next trigger pulse. This is also the case when the STABILITY control is set at PRESET.

For synchronized operation of the time-base generator, as used in the H F SYNC position, set the STABILITY control to the advanced position so that the generator just free-runs, and keep it to the right of this point while adjusting its point to synchronize the time base.

For all triggered operation except AUTO., the STABILITY control should be retarded to the left of the free run point or set to the PRESET position (S/N 1001-up).

General-Purpose Triggering

For most average triggering applications the AUTO. mode of triggering is the easiest to use. Only one control need be adjusted and after it is once set the sweep will trigger satisfactorily on a wide variety of waveforms and over a wide range of sweep speeds without resetting. When the STABILITY control is set properly there will always be a trace on the screen, whether a signal is present or not, unless the trace is positioned off the screen vertically. This feature is especially valuable if the probe is being moved from one point to another in a circuit under test.

To use the AUTO. mode, set the red TRIGGER SELECTOR knob to AUTO. A horizontal trace should appear immediately. A stable display should be obtained on most signals within the range of 60 cycles to 2 megacycles when using this mode.

For any application within the frequency range from 60 cycles to about 5 megacycles where the display is unstable on AUTO., the AC mode can be used. To use this mode of triggering, proceed as follows:

1. Set the red TRIGGER SELECTOR knob to AC.
2. Set the STABILITY control to the PRESET position (counterclockwise S/N 101-1000).
3. Adjust the TRIGGERING LEVEL control for stable triggering.

The procedure outlined above will provide stable triggering for most applications. However, with some triggering waveforms, it may be necessary to manually set the STABILITY control. This is done as follows:

1. Set the red TRIGGER SELECTOR knob to AC.
2. Turn the TRIGGERING LEVEL control counterclockwise to the stop.
3. Advance the STABILITY control clockwise until the time-base generator free-runs then back it off just past the point where the sweep stops.
4. Turn the TRIGGERING LEVEL control clockwise until stable triggering occurs. With this same control you can now select the point or level at which triggering occurs. Triggering should occur near the 0 mark.

Low-Frequency Triggering

For waveforms having a slow rise and a repetition rate of less than 60 cps, the DC triggering mode is best.

To use this mode of triggering, proceed as follows:

1. Set the red TRIGGER SELECTOR knob to DC.
2. Set the STABILITY control to the PRESET position (counterclockwise S/N 101-1000).
3. Adjust the TRIGGERING LEVEL control for stable triggering.

The procedure outlined above will provide stable triggering for most applications. How-

ever, with some triggering waveforms, it may be necessary to manually set the STABILITY control. This is done as follows:

1. Set the TRIGGER SELECTOR red knob to DC.
2. Turn the TRIGGERING LEVEL control counterclockwise to the stop.
3. Advance the STABILITY control clockwise until the time-base generator free-runs then back it off just past the point where the sweep stops.
4. Turn the TRIGGERING LEVEL control clockwise until stable triggering occurs. With this same control you can now select the point or level at which triggering occurs. Triggering should occur near the 0 mark if the trace is centered.

Since the AC mode is more sensitive than the DC mode above 60 cps and is not affected by the positioning controls, it is superior to the DC mode, above 60 cps. However, the DC mode can be used up to about 5 mc.

High-Frequency Synchronization

For stable triggering it is necessary for the trigger circuits to have a frequency response considerably in excess of the frequency of the waveform being displayed. At about five megacycles the efficiency of the trigger circuits is reduced and the H F SYNC mode becomes the best method of synchronizing the trace. To use the H F SYNC mode simply advance the STABILITY control until the time base free-runs and then continue to advance it until the time base locks in with the signal. The polarity markings on the TRIGGER SELECTOR switch have no significance in this mode, and the TRIGGERING LEVEL control is not used.

Triggering on Complex Waveforms

When the waveform under observation is complex there may be several points on the waveform where ordinary triggering circuits may tend to trigger. As a result, the trace may be unstable. This instability may be encountered occasionally with the AUTO. mode of triggering. The AC and DC triggering modes allow the level on a waveform, at which triggering occurs, to be selected by the TRIGGERING

LEVEL control. Thus the LEVEL control can be set so that only one point on the waveform is of sufficient amplitude to trip the triggering circuits. This point can be located by setting the controls as for the AC or DC triggering modes and then moving the TRIGGERING LEVEL control away from the 0 mark in either direction until the trace becomes stable.

Trigger-Signal Source

For most normal triggering applications the INT. trigger source is most convenient. In the INT. positions of the TRIGGER SELECTOR switch the triggering signal is obtained from the vertical amplifier.

If an external trigger source is available it is often convenient to use the EXT. positions of the TRIGGER SELECTOR switch. An external trigger source is particularly useful if the amplitude of the signal under observation is changing or if the probe is being moved from point to point in a circuit.

The LINE positions of the TRIGGER SELECTOR switch permit stable triggering at the line frequency. These positions are useful when displaying almost any function that is synchronized with the line.

TIME-BASE OPERATION

General

The time-base generator produces the saw-tooth waveform which is used to move the beam across the crt. The TIME/CM controls vary the slope, but not the amplitude, of this waveform, and thus determine the sweep rate without affecting the length greatly.

The horizontal amplifier amplifies the saw-tooth waveform and applies it to the crt deflection plates. The HORIZ. DISPLAY switch increases the gain of the amplifier five times in the MAG. position. In this position the display is spread over the equivalent of five screen diameters.

Sweep Rate

The TIME/CM controls determine the sweep rate of the horizontal trace. The TIME/CM of horizontal deflection is indicated by the black numbers when the HORIZ. DISPLAY

switch is in the normal position and by the blue numbers when it is in the MAG. position. These numbers are correct only when the red VARIABLE control is completely clockwise. The UNCALIBRATED light indicates when the time base is not calibrated for this reason. The VARIABLE control has a range of about 2 1/2 to 1.

Magnifier

The HORIZ. DISPLAY switch increases the horizontal-amplifier gain five times in the MAG. position expanding the time base so that the center one-fifth of the trace fills the graticule. The MAG. light is energized when the HORIZ. DISPLAY switch is turned to the MAG. position. Any portion of the trace may be positioned on the screen with the HORIZONTAL POSITIONING control. If the VARIABLE control is fully clockwise the magnified sweep rate is indicated by the blue numbers at the TIME/CM switch.

External Horizontal Input

When the HORIZ. DISPLAY switch is in the EXT. position, the horizontal amplifier is connected to the EXT. HORIZ. INPUT binding post. The STABILITY control serves as an attenuator for signals applied to this binding post.

VERTICAL-AMPLIFIER OPERATION

Probes

The P6000 probe furnished with this instrument has a 10-to-1 attenuation ratio. Be sure to check the adjustment of the probe regularly and before making critical measurements. If the compensation is incorrect the frequency response will be affected. Touch the probe tip to the calibrator output connector and display several cycles of the calibrator waveform. If the top and bottom of the displayed square wave are not flat, adjust the trimmer capacitor located inside the probe body to achieve correct square-wave response.

Input Connections

Be careful that the external circuitry does not cause deterioration of the waveform when you make connections to the INPUT connectors. Improper termination of cables may cause ring-

ing or loss of frequency response. If you use unshielded leads keep them as short as possible.

Two cables or probes can be connected to the oscilloscope at once. You can then select the signal on either cable with the INPUT SELECTOR switch. However, if one signal is very much larger than the other, some crosstalk may occur and the cable having the larger signal should be disconnected.

Coupling

It is sometimes unnecessary or undesirable to display the dc level of the waveform. In the two AC positions of the INPUT SELECTOR switch, a capacitor in series with the input blocks the dc component of the waveform so that only the ac component is displayed.

Deflection Sensitivity

The VOLTS/CM switch inserts frequency-compensated attenuators ahead of the amplifier. The VARIABLE control provides continuous adjustment of the deflection sensitivity between the values indicated by the VOLTS/CM switch. The VARIABLE control must be clockwise against the stop for the sensitivity to be as indicated by the VOLTS/CM switch. The red UNCALIBRATED light indicates when the VARIABLE control is not fully clockwise.

DC Balance Adjustment

After the oscilloscope has been in use for a period of time you will notice that the trace will change position as the VARIABLE control is rotated. This is caused by tube aging and the resultant shift in operating potentials. To correct this condition rotate the VARIABLE control back and forth and adjust the DC BAL control until the trace position is no longer affected by rotation of the VARIABLE control.

AUXILIARY FUNCTIONS

Square-Wave Calibrator

The square-wave calibrator provides a source of square waves of known amplitude at about

1000 cycles. The output impedance varies with the voltage but is as high as 5,000 ohms. Be sure the load impedance you connect to the CAL. OUT connector does not change the output voltage.

Trace-Brightness Modulation

To couple markers or other signals into the crt cathode for brightness information, disconnect the ground strap at the rear of the instrument and connect the signal to the CRT CATH. binding post.

Graticule Illumination

The graticule lighting control, labeled SCALE ILLUM., can be adjusted to suit the lighting conditions of the room. The graticule can be mounted in either of two positions rotated 180 degrees from each other. In one position the illumination is colored red and, in the other position, white. The white will reproduce well photographically.

A green light filter is supplied which can be used for increased contrast. Normally this filter should be mounted next to the crt screen so it does not block the light from the graticule lines.

Direct Connection to Deflection Plates

Connections can be made directly to the deflection plates by removing the cabinet on the left side. The two pins on the left-hand side of the crt neck are the vertical deflection plates. To avoid distortion, the average dc potential on these plates should be between 150 and 200 volts. Unless dc coupling is required, connect coupling capacitors in series with the leads to the deflection plates and connect one-megohm resistors from the deflection plates to the leads from the delay line. With this connection the plates are maintained at the proper operating potential and positioning control is retained by the front-panel controls.

CIRCUIT DESCRIPTION

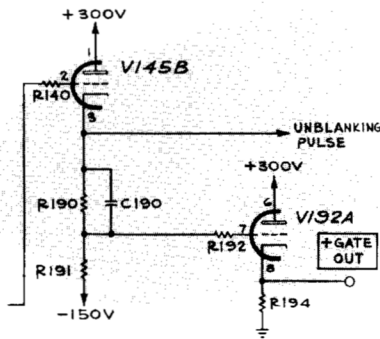
**BLOCK DIAGRAM DESCRIPTION**

The block diagram shows the interconnection of the functional parts of the oscilloscope, except the power supplies. Functions of the switches are shown instead of their actual connections. This diagram, as well as the ones which follow, is designed to fold out so that the diagram can be studied along with the text without turning any pages.

The vertical amplifier has a sensitivity of .05 volt per centimeter (.1 volt per centimeter S/N 101-1000) and provides push-pull output to drive the deflection plates. The balanced delay line is connected between the output amplifier and the deflection plates.

The trigger cathode follower applies a sample of the vertical signal to the trigger-amplifier stage to provide internal triggering.

The trigger amplifier and shaper provide a sharp trigger pulse which triggers the multivibrator. The multivibrator gates the time-base generator and is prevented from recycling by the holdoff cathode follower until the generator has had time to run up and return.

The time-base generator is a Miller run-up type and provides a 150-volt sawtooth for the horizontal amplifier.

The horizontal amplifier converts the time-base sawtooth for push-pull applications to the deflection plates.

The unblanking cathode follower applies a positive gate to the crt grid via the high-voltage power supply. It also supplies a gate to the gate-out cathode follower which provides a positive gate at a front-panel binding post.

The calibrator provides a square wave of known amplitude for checking the gain of the oscilloscope amplifiers and auxiliary equipment.

VERTICAL-DEFLECTION SYSTEM**General**

The Type 515/515A vertical amplifier has a maximum sensitivity of .05 volt per centimeter (.1 volt per centimeter S/N 101-1000), ac or dc. The circuit consists of two stages of amplification, each stage preceded by cathode followers.

Input Connectors

There are two input connectors which can be switched into the input circuits by SW 301, the INPUT SELECTOR switch. This switch is wired physically so as to reduce coupling between inputs to a minimum. Blocking capacitor C301 is shorted out in the DC positions of the selector switch.

Input Attenuators

The VOLTS/CM switch inserts frequency-compensated attenuators into the input circuit. Four attenuators are used singly or in tandem pairs to produce nine fixed sensitivities.

DC Balance

The DC BAL control, R338, provides an adjustable, dc grid voltage for V340 so that the cathode of V360 is at the same potential as the cathode of V350. When this control is properly set, no change in vertical positioning will result when the VARIABLE position is rotated.

Input Cathode Follower

The input cathode follower, V330, isolates the input circuits from changes in capacitance as the VARIABLE control is rotated. R330 is a current-limiting resistor to limit grid current in the event an excess voltage is applied to the input. The opposite cathode follower, V340, balances the drift in V330 caused by heater-voltage changes.

Input Amplifier

The input amplifier stage is a common-cathode phase-splitter amplifier. Coils L351 and L361 provide high-frequency peaking. The VARIABLE VOLTS/CM control, R356, varies the gain by varying the degeneration in the cathode circuit.

Vertical positioning is produced by two dual potentiometers, R368, connected to the plates of the amplifier so that current through one plate load is increased as current through the other plate load is decreased. Since the amplifier is dc coupled, the change in the plate voltage which occurs changes the position of the trace on the cathode-ray tube.

The rc networks, R352, C352 and R362, C362, provide compensation for the reduction in gain at very-low frequencies which is a characteristic of high-conductance amplifiers.

Output Amplifiers

Cathode followers V370A and V370B drive the output amplifiers through series peaking coils L390 and L400. The GAIN ADJ. control, R396, sets the gain of the amplifier to agree with the front-panel calibration. Plate current for the output amplifiers is supplied by the delay-line termination resistors, R485 and R486.

Delay Line

The balanced delay line delays the signal until the sweep starts and the crt is unblanked. The trigger signal is taken from a coil which serves as the first section of the delay line. Each section of the line is turned for optimum response to a square wave.

HORIZONTAL-DEFLECTION SYSTEM

Trigger Amplifier

The TRIGGER SELECTOR switch with the black knob, SW20, selects the source of triggering voltage and arranges the trigger-amplifier input circuit to produce negative-going output for either negative-going or positive-going portions of the input signal.

The trigger amplifier, V10, is a grounded-grid cathode-coupled amplifier. A capacitor, C4, can be switched into the grid circuit to remove the dc component of the trigger signal. Output is always taken from the pentode plate, but the TRIGGER SELECTOR switch connects either the pentode grid or the triode grid to the input-signal source. The opposite grid is connected to a dc bias source, adjustable by means of the TRIGGERING LEVEL control. This bias voltage determines the voltage on the pentode plate. In the AC and DC positions of the TRIGGER SELECTOR switch, the voltage on the pentode plate is dc coupled to the grid of V30A.

Trigger Shaper

The trigger-shaper stage consists of V30 connected as a dc-coupled multivibrator. In the normal, or quiescent, state the V30A section is conducting and its plate is down. The grid of the V30B section is dc coupled to the V30A plate through divider R38, R39 and R40, which holds the "B" grid below plate-current cutoff. As the trigger signal drives grid of V30A in the negative direction the cathodes of both tubes follow the grid down until V30B starts to conduct. At this point the plate voltage of V30A and the B grid rises with it. The V30B cathode rises with its grid carrying the "A" cathode with it and V30A cuts off. The transition occurs very rapidly, regardless of how slowly the V30A grid signal falls.

The steep negative-going step at the plate of V30B is differentiated by an rc network including C109 shown in the sweep diagram, and the sharpened pulse trips the sweep multivibrator.

Trigger Mode Switch

The TRIGGER SELECTOR switch with the red knob, SW5, has four positions which arrange

the circuits for four types, or modes, of triggering. In the DC position, the triggering signal is dc coupled as far as the trigger-shaper stage. In the AC position, blocking capacitor C4 removes the dc component of the signal.

In the AUTO. position of SW5, the plate of the A section of the trigger shaper, V30, drives the grid of the B section just as it also drives its own grid through R45, a resistance of several megohms. This plate-to-grid coupling allows the trigger shaper to free-run when no triggering signal is present. The addition of R45 causes the trigger shaper to free run when no trigger signal is present. For example, when the plate of V30A rises, the grid of V30B also rises, carrying with it the right-hand end of R45. The left-hand end of R45 is connected to the A grid through R22. The time constant of the rc circuit between the B grid and ac ground through C20, R22 and R45 is of such length that it takes about .01 second for the V30A grid to rise exponentially from its starting point below cutoff to a point where plate current can flow.

When V30A plate current flows, the plate drops, forcing the V30B grid down, and thus the right-hand end of R45 is forced down. The left-hand end of R45 and the A grid immediately begin to drop exponentially toward cutoff. When the A grid reaches cutoff again it has completed one cycle of the approximately 50-cycle triangular waveform. The range of the V30A grid voltage between A cutoff and B cutoff is about 3 volts for the circuit used in the AUTO. mode. This is increased from about .5 volt for the AC and DC modes by the addition of R45 to the circuit.

Since the V30A grid is never more than 3 volts from cutoff, a trigger signal with a peak-to-peak voltage of three volts or more can drive the grid to cutoff at any time and produce a trigger output. Smaller signals can also trigger the shaper but only if they occur at a time when the grid is within their peak voltage of cutoff. The duty cycle of operation of the time-base generator is somewhat reduced therefore with smaller trigger signals.

This circuit configuration is useful because with it the time-base generator can be synchronized with repetitive signals over a wide range of frequencies without readjustment. When

not triggered externally, the generator continues at a 50-cycle rate, and in the absence of any vertical signal, generates a base line that shows that the oscilloscope is adjusted so as to display any signal that might be connected to the vertical-deflection system.

In the H F SYNC position of SW5, the trigger amplifier and trigger shaper stages are bypassed and the trigger signal is applied directly to the sweep multivibrator. In this mode the STABILITY control is set so the sweep is superimposed on the negative-going trigger-holdoff waveform at the grid of V110A and will cause the multivibrator to synchronize at a submultiple of the triggering signal frequency. This circuit is suitable for signals in excess of five megacycles.

Schmitt Multivibrator

The dc-coupled multivibrator, shown in the time-base diagram, turns on the time-base generator upon receipt of a negative trigger from the trigger shaper, and holds off subsequent trigger signals until after the sweep is completed. The multivibrator consists of V110A and V120 with both common-cathode and plate-to-grid coupling. Plate-to-grid coupling is by means of a cathode follower.

In the quiescent state V110A is conducting and its plate is down. Cathode-follower V110B holds the grid of V120B below cutoff through voltage divider R115, R116. Cathode-follower V110B isolates the plate of V110A from the various loads, and thereby permits a faster step.

When the negative trigger pulse from the trigger-shaper stage reaches the grid of V110A it is coupled to V120B and V120B starts to conduct. The multivibrator switches quickly to its second state with V120B conducting and V110A cut off. The biases and plate loads are adjusted so that when V110A is conducting, the grid of V120B is held below cutoff, and when V120B is conducting the cathode of V110A is held above cutoff.

There are thus two stable states, in either of which the multivibrator will remain until a signal of the proper polarity and amplitude to the grid of V110A switches it to the other state. To return the multivibrator back to the quiescent state with V110A conducting, a

positive voltage is required at the grid of V110A which is high enough to cause plate current to flow. The positive voltage for returning the multivibrator to its quiescent state is supplied from the time-base generator when it has completed its sweep.

The STABILITY and PRESET controls adjust the grid voltage of V110A near the point of free running.

Time-Base Generator

The time-base generator is a Miller integrator circuit. The circuit includes disconnect diodes V150A and V150B, cathode-follower V160A, timing capacitor C160 and the Miller tube, V160B. In the quiescent state between sweeps, the plates of diodes V150A and V150B rest at -2.5 volts. Very little current flows through V150B to the grid circuit of V160B, and the grid of V160B rests at -2.5 volts. More current flows through V150A so that its cathode is about .5 volt lower at -3 volts. The timing capacitor, C160, which is connected between these two points, therefore has a charge of about .5 volt.

The grid of cathode-follower V160A is connected to the plate of Miller tube V160B through neon glow tube B160. The grid of V160A therefore follows the plate changes of V160B but remains 55 volts below the plate. Network C161, R161, improves the risetime of the circuit.

The -2.5 volt bias on the grid of V160B places the tube in the class A region of its operating characteristic, where the plate-to-cathode voltage is inversely proportional to the grid to cathode voltage. The plate rests at about +55 volts. The negative step from the multivibrator to the plates of diodes V150A and V150B lowers the plates below their cathodes and they no longer conduct. The Miller-tube grid, and the cathode follower are thus released to seek their own voltage levels. The grid of Miller tube V160B, which is returned to -150 volts through R150, starts negative. When the grid starts negative the plate starts positive carrying cathode-follower V160A grid and cathode positive. This raises the top end of C160 positive which thus tends to prevent the Miller tube grid from going negative.

The gain of the Miller tube as a class-A amplifier is so high that the plate signal

coupled back through charging capacitor C160 keeps the grid voltage constant within a fraction of a volt. Meanwhile, C160 is charging with current through R150 from the -150-volt bus. Since the grid of V160B remains constant within a fraction of a volt, the current through R150 remains constant, and C160 thus charges at a constant rate. As C160 charges the voltage of the upper end therefore rises linearly. Any departure from a linear rise of the cathode of cathode follower V160A will result in a change in Miller-tube grid voltage in the direction that will correct for the error. A bootstrap capacitor, C165, increases the plate current in V160B at the higher sweep speeds to help maintain a linear voltage rise.

The linear rise of the cathode of V160A is used as the time-base sawtooth. Charging capacitor C160 is selected by means of a step switch, SW155, labeled TIME/CM on the front panel. Charging resistor R150 is also selected by the TIME/CM switch so that both the size of the capacitor being charged and the current charging the capacitor can be selected to cover a wide range of sawtooth slopes.

The cathode of V160A continues to rise linearly until a positive step from the multivibrator, V120B, returns the disconnect diode plates back to their quiescent state raising the Miller tube grid. When the Miller tube grid rises, its plate drops carrying cathode-follower V160A with it until its cathode clamps again through V150A at the quiescent level of -2.5 volts. The Miller-tube plate will always rest at about +55 volts after the sweep, because, as V150A begins to conduct, its plate drops slightly. This reduced plate voltage allows the Miller-tube grid to go slightly more negative, stopping the fall in plate voltage.

Sawtooth Amplitude

The positive step from multivibrator V120B, which stops the sweep, occurs when a positive voltage is delivered to the grid of multivibrator V110A. The time-base sawtooth is applied to the multivibrator through cathode followers V140A and V140B from a tap on the cathode-load resistor of V160A. This tap is adjustable by means of potentiometer R156, labeled Sawtooth Amplitude, a screwdriver adjustment. When the voltage of this tap is properly set, the sawtooth will terminate when the spot has passed the right-hand limit of the graticule. C130 on the grid of V140B retards the return

of V140B grid to the quiescent level after the passage of the positive voltage. This prevents any trigger signals from retriggering the multivibrator until all other capacitances in the circuit have had time to reach their quiescent voltage levels. Proper sizes of capacitor C131 are switched with the TIME/CM switch so that more recovery time is permitted for the slower sweep rates and the least necessary recovery time is allowed for the faster sweep rates.

Horizontal Amplifier

The time-base waveform passes through the frequency-compensated positioning network, R210, R211, to the grid of cathode-follower V210B. This cathode follower provides the necessary low impedance to drive the switch capacitances and the second cathode follower, V210A. In the NORM. position of the HORIZ. DISPLAY switch, an attenuation network is inserted between the cathode of the Input C.F., V210B and the Driver C.F., V210A. In the MAG. position of the HORIZ. DISPLAY switch, this attenuator network is bypassed, so that the amplitude of the input signal to the Amplifiers is multiplied by a factor of five. In the EXT position, the HORIZ. DISPLAY switch connects the amplifier to the EXT. HORIZ. INPUT binding post to display the signal applied to this binding post.

Cathode-follower V210A applies the signal to the output amplifier, V250A and V270A. The output amplifier, converts the signal for push-pull application to the deflection plates. R259 varies the degeneration in the cathode circuits to set the gain of the amplifier. C260 provides high-frequency compensation of the output amplifier by reducing the high-frequency degeneration. R214B provides horizontal positioning when the HORIZ. DISPLAY switch is in the EXT. position.

The waveform at the plates of the output amplifier is applied to the crt horizontal-deflection plates via cathode followers V250B and V270B. Bootstrap capacitors C246 and C272 increase the current in the output amplifiers at the high sweep rates to improve time-base linearity. Neon diodes NE253 and NE280 protect the cathode followers from excess grid to cathode voltage when the instrument is first turned on.

CALIBRATOR

The calibrator is a symmetrical multivibrator with V550A and V550B connected so as to turn cathode-follower V570 on and off as it oscillates. During the negative pulse at multivibrator V550A, the grid of the cathode follower is driven well below cutoff, so the cathode is at ground voltage. During the positive pulse at the multivibrator, the plate is cut off and rests slightly below +100 volts. The voltage of the plate during cutoff is determined by the setting of R560, part of a divider between +100 volts and ground. R560 is a screwdriver adjustment labeled CAL. ADJ.

Cathode follower V570 has a tapped, calibrated voltage divider for its cathode resistor. When the CAL. ADJ. control is properly set, the cathode-follower cathode is at +100 volts when V510B is cut off. The taps on the divider provide eleven fixed calibrated amplitudes. No internal connection from the calibrator to the vertical-deflection circuits is provided.

POWER SUPPLY

Transformer

Plate and heater power for the Type 515/515A is provided by a single power transformer, T600. The transformer has two equal 117-volt windings that can be connected either in parallel for 117-volt operation, or in series for 234-volt operation.

Rectifiers

The ac voltage from the high-voltage windings is rectified by bridge-connected full-wave selenium rectifiers.

-150-Volt Supply

All dc voltage furnished by the power supply are regulated with the exception of the +360-volt supply which is used only to supply circuits which are insensitive to voltage variations. Reference voltage for the regulators is established by means of a gas-diode voltage reference tube, V602. The voltage-reference tube determines the grid voltage of a comparator amplifier, V607, in the -150-volt supply.

The grid potential of V607B is compared with the voltage obtained from a divider, R616,

R617, R618, between the -150-volt bus and ground. R617, labeled -150 ADJ., determines the percentage of the total voltage that appears at the grid of V607A and thus determines the total voltage across the divider.

The voltage difference between the two grids of V607 appears as an amplified error signal at the plate of V607B. The amplified error signal is dc coupled to the grid of the series-regulator tube, V610. This dc-coupled error signal controls the plate resistance of the series regulator tube, changing it in the right direction to compensate for any change in output voltage. C613 increases the ac gain of the feedback loop to reduce the ripple.

The screen of V607B has a small amount of the ripple that exists ahead of the series regulator tube connected to it through R605. The phase of this ripple is such as to reduce the ripple of the -150-volt bus. This circuit also improves the regulation in the presence of line-voltage variation. R620 bypasses the series tube to reduce the amount of load current through it.

+100-Volt Supply

The -150-volt supply serves as reference voltage for the +100-volt supply. The voltage at the tap on the voltage divider, R639, R640, is applied to the grid of V631. The error signal is amplified in V631 and applied to the grid of V635B, the series-regulator tube. R633, at the screen of V631, reduces ripple and improves the regulation of the supply. C636 increases the ac gain of the feedback loop.

+300-Volt Supply

Rectified voltage from terminals 8 and 9 of the power transformer is added to the voltage supplying the +100-volt regulator to provide about 400 volts for the +300-volt regulator and other points in the instrument which do not need a regulated voltage. The +300-volt circuit is similar in operation to the +100-volt regulator.

CRT CIRCUIT

High-Voltage Supply

Accelerating voltage for the cathode-ray tube is obtained by rectifying a 60-kc voltage pro-

duced by a vacuum-tube oscillator. V705 is the oscillator tube with the primary of T701 serving as a tapped inductor. Rectifier V720 supplies -1675 volts to the crt cathode and V721 supplies +2325 volts to the post-acceleration helix to provide a total acceleration voltage of 4000 volts.

High-Voltage Regulator

A divider from the crt cathode to the +300-volt bus applies a sample of the negative accelerating voltage to the grid of V710B. R741 varies the voltage at the tap to adjust the high voltage. The -150-volt supply, connected to the cathode of V710B, serves as a reference voltage. The amplified error signal at the plate of V710B is applied to the grid of the shunt regulator tube, V710A. The shunt regulator tube determines the screen voltage of the oscillator tube and thus controls the oscillator output voltage.

If, for example, the output voltage becomes too high, the regulator reduces the voltage on the screen of the oscillator tube. The output voltage of the oscillator decreases and the output voltage is corrected.

Unblanking

The crt control-grid voltage is produced by a winding and rectifier, V724, similar to the cathode supply but insulated from it. The positive end of the control-grid supply is connected to the unblanking cathode follower. When the unblanking pulse is produced at the cathode of the unblanking cathode follower, it drives the whole grid-voltage supply with it so that the pulse appears at the crt grid. Since this is a dc connection, the unblanking pulse can have any duration with no change in grid voltage. The INTENSITY control, R731, varies the bias on the grid to determine trace brightness.

CRT Geometry Control

The second-anode voltage required for best linearity at the extremes of deflection may vary somewhat between tubes. R753, labeled GEOM. ADJ. on the chassis, permits this voltage to be adjusted.

MAINTENANCE

PARTS ORDERING AND REPLACEMENT

Instruction Manual

A Tektronix instruction manual usually contains hand-made changes to diagrams and parts lists, and sometimes test. These changes are in general appropriate only to the instrument the manual was prepared for. These hand-made corrections show changes in the instrument that have been made after the printing of the manual.

There is a serial number on the frontispiece and on the warranty page of this manual. This is the serial number of your instrument. Be sure the manual number matches the instrument number when you order parts.

NOTE

Always include the instrument type and SERIAL NUMBER in any correspondence regarding the instrument.

Standard Components

Tektronix will supply replacement components at current net prices. However, since most of the components are standard electronic and radio parts you can probably obtain them locally faster than we can ship them to you from the factory in Portland, Oregon. Be sure to consult the instruction manual to see what tolerances are required.

Selected Components

We specially select some of the components, whose values must fall within prescribed limits, by sorting through our regular stocks. The components so selected will have standard RETMA color coding showing the value and tolerance of the stock they were selected from, but they will not in general be replaceable from dealer's stocks.

Checked Tubes

To obtain maximum reliability and performance we check some of the vacuum tubes used in our instruments for such characteristics as microphonics, balance, transconductance, etc. We age other tubes to stabilize their characteristics. Since there are no well defined standards of tube performance we have established our own arbitrary standards and have developed equipment to do this checking. These checked tubes can be purchased through our local Field Engineering Offices or directly from the factory in Portland, Oregon.

Tektronix Manufactured Parts

Tektronix manufactures almost all of the mechanical parts and some of the components used in the instrument. If you order a mechanical part be sure to describe the part completely to prevent any unnecessary delay in filling your order. When you have any questions about mechanical parts or Tektronix manufactured components contact our nearest Field Engineering Office or write to the Field Engineering Department at the factory in Portland, Oregon.

MECHANICAL MAINTENANCE

Air Filter

The Type 515/515A is cooled by filtered forced air. The air filter is constructed of aluminum wool coated with adhesive. If the filter gets too dirty it will restrict the flow of cooling air and cause the instrument to overheat. The filter should be inspected every three or four weeks at first and cleaned if necessary. A periodic inspection schedule should be established based on the dust conditions in your work area.

To clean the filter, run hot water through it from the side that was inside. Or slosh

it around in hot soapy water and rinse it in clear water. Then dry it thoroughly and coat it with new adhesive. When new, the filter is coated with "Filter Coat", a product of the Research Products Corporation. "Filter Coat" should be easy to get locally; look in the classified section of your telephone book for RP Air Filters, or EZ Kleen Air Filters. Other adhesive materials are no doubt satisfactory.

Fan Motor

The fan motor bearings will require oiling every few months or every thousand hours of operation. Use a good grade of light machine oil and apply only a drop or two.

GENERAL INFORMATION

Color Coding

We use color coded wires in the instruments to help identify the various circuits. These wires will be either a solid color or will be a solid color (including black and white) with one or more colored stripes. The colored stripes are "read" in the same manner as the RETMA resistor color code. In the case of multiple stripes the wide stripe is read first.

Wires carrying positive regulated-power-supply voltages are white and the stripes indicate the supply voltage. For example, the +225-volt supply bus will be coded red-red-brown (2-2-1) giving two significant figures and the decimal multiplier.

The negative-supply bus wires are black and the stripes indicate the supply voltage. For example, our most common negative-supply voltage is -150 v and is carried by a black wire coded brown-green-brown (1-5-1).

The mains-voltage leads to the power transformer are yellow and coded brown-brown-brown (1-1-1).

The tube heater leads are white and coded 6-1, 6-2, 6-3, etc., not to indicate that the voltages are different but to differentiate between circuits.

In other respects the color coding will vary from instrument to instrument. In general

all signal-carrying leads are white and coded with a single colored stripe. In a few places where the number of leads exceeded the capabilities of single-stripe coding we have used solid-color leads.

Soldering and Ceramic Strips

Many of the components in your Tektronix instrument are mounted on ceramic terminal strips. The notches in these strips are lined with a silver alloy. Repeated use of excessive heat, or use of ordinary tin-lead solder will break down the silver-to-ceramic bond. Occasional use of tin-lead solder will not break the bond if excessive heat is not applied.

If you are responsible for the maintenance of a large number of Tektronix instruments, or if you contemplate frequent parts changes, we recommend that you keep on hand a stock of solder containing about 3% silver. This type of solder is used frequently in printed circuitry and should be readily available from radio-supply houses. If you prefer, you can order the solder directly from Tektronix in one-pound rolls. Order by Tektronix part number 251-514.

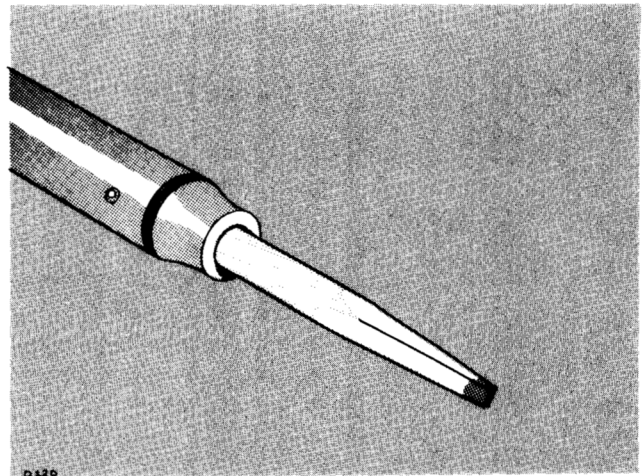

Fig. 4-1. Soldering iron tip properly shaped and tinned.

Because of the shape of the terminals on the ceramic strips it is advisable to use a wedge-shaped tip on your soldering iron when you are installing or removing parts from the strips. Fig. 4-1 will show you the correct shape for the tip of the soldering iron. Be sure and file smooth all surfaces of the iron

which will be tinned. This prevents solder from building up on rough spots where it will quickly oxidize.

When removing or replacing components mounted on the ceramic strips you will find that satisfactory results are obtained if you proceed in the manner outlined below.

1. Use a soldering iron of about 75 -watt rating.

2. Prepare the tip of the iron as shown in Fig. 4-1.

3. Tin only the first 1/16 to 1/8 inch of the tip. For soldering to ceramic terminal strips tin the iron with solder containing about 3% silver.

4. Apply one corner of the tip to the notch where you wish to solder (see Fig. 4-2).

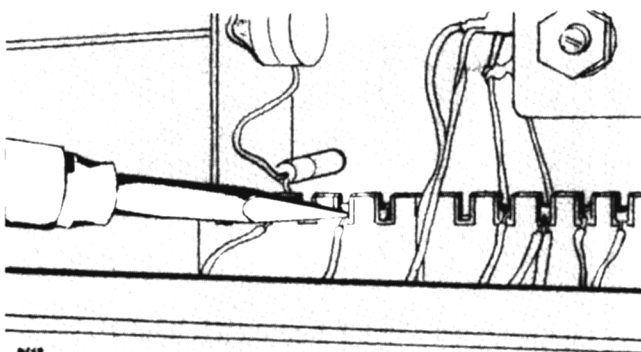

Fig. 4-2. Correct method of applying heat in soldering to a ceramic strip.

5. Apply only enough heat to make the solder flow freely.

6. Do not attempt to fill the notch on the strip with solder; instead, apply only enough solder to cover the wires adequately, and to form a slight fillet on the wire as shown in Fig. 4-3.

In soldering to metal terminals (for example, pins on a tube socket) a slightly different technique should be employed. Prepare the iron as outlined above, but tin with ordinary tin-lead solder. Apply the iron to the parts to be soldered as shown in Fig. 4-4. Use only enough heat to allow the solder to flow freely

along the wire so that a slight fillet will be formed as shown in Fig. 4-4.

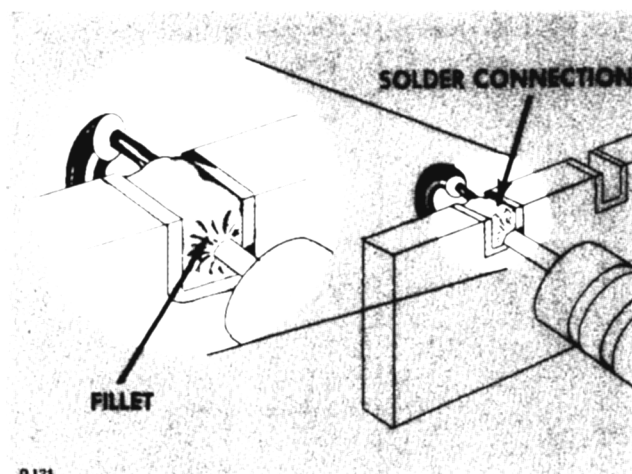

Fig. 4-3. A slight fillet of solder is formed around the wire when heat is applied correctly.

General Soldering Considerations

When replacing wires in terminal slots clip the ends neatly as close to the solder joint as possible. In clipping the ends of wires take care the end removed does not fly across the room as it is clipped.

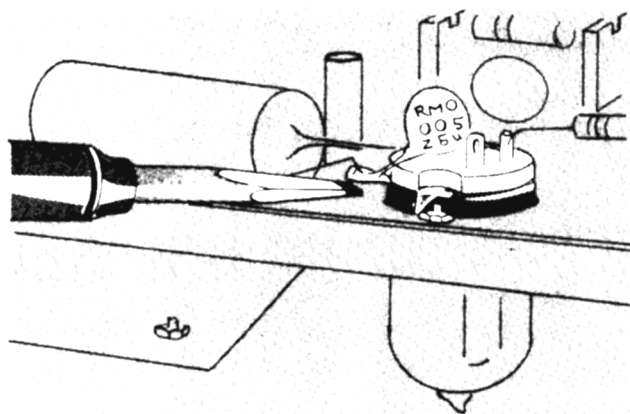

Fig. 4-4. Soldering to a terminal. Note the slight fillet of solder--exaggerated for clarity--formed around the wire.

Occasionally you will wish to hold a bare wire in place as it is being soldered. A handy device for this purpose is a short

length of wooden dowel, with one end shaped as shown in Fig. 4-5. In soldering to terminal pins mounted in plastic rods it is necessary to use some form of "heat sink" to avoid melting the plastic. A pair of long-nosed pliers (see Fig. 4-6) makes a convenient tool for this purpose.

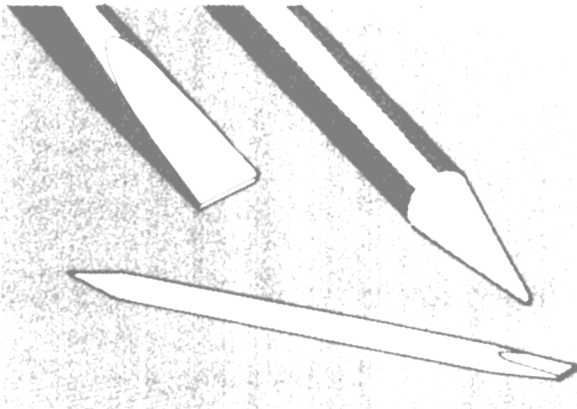

Fig. 4-5. A soldering aid constructed from a 1/4 inch wooden dowel.

Ceramic Strips

Two distinct types of ceramic strips have been used in Tektronix instruments. The earlier type mounted on the chassis by means of #2-56 bolts and nuts. The later type is mounted with snap-in, plastic fittings. Both styles are shown in Fig. 4-7.

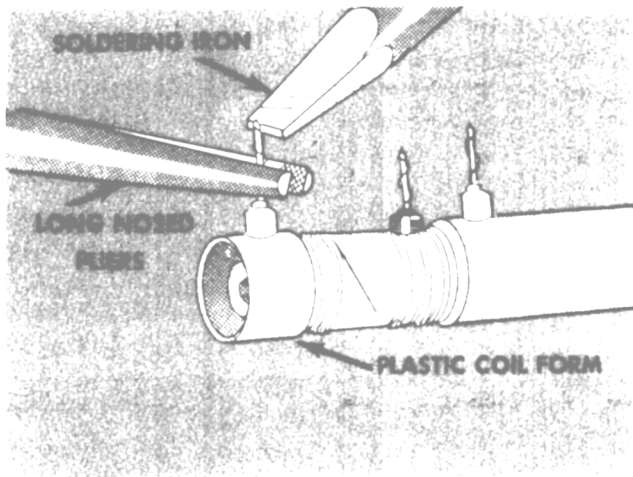

Fig. 4-6. Soldering to a terminal mounted in plastic. Note the use of the long-nosed pliers between the iron and the coil form to absorb the heat.

To replace ceramic strips which bolt to the chassis, screw a #2-56 nut onto each mounting bolt, positioning the nut so that the distance between the bottom of the nut and the bottom of the ceramic strip equals the height at which you wish to mount the strip above the chassis. Secure the nuts to the bolts with a drop of red glyptal. Insert the bolts through the holes in the chassis where the original strip was mounted, placing a #2-56 starwasher between each nut and the chassis. Place a second set of #2-56 flatwashers on the protruding ends of the bolts, and fasten them firmly with another set #2-56 nuts. Place a drop of red glyptal over each of the second set of nuts after fastening.

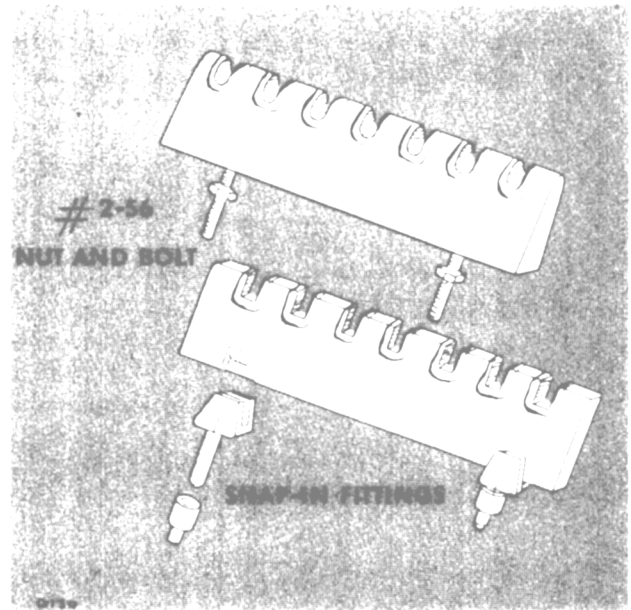

Fig. 4-7. Two types of ceramic strip mountings.

Mounting Later Ceramic Strips

To replace strips which mount with snap-in plastic fittings, first remove the original fittings from the chassis. Assemble the mounting post on the ceramic strip. Insert the nylon collar into the mounting holes in the chassis. Carefully force the mounting post into the nylon collars. Snip off the portion of the mounting post which protrudes below the nylon collar on the reverse side of the chassis.

NOTE

Considerable force may be necessary to push the mounting rods into the nylon collars. Be sure that you apply this force to that area of the ceramic strip directly above the mounting rods.

Removing the Cabinet

Each side panel and the bottom panel are individually removable when service becomes necessary. To remove a side panel release the fasteners near the front and back and swing the top of the panel out until the bottom hinge releases. To remove the bottom panel release the four fasteners and lift the panel off.

To replace the panels, reverse the process above. Each fastener is designed so that the first one-quarter turn engages an ear on the fastener with the oscilloscope frame. Further turning of the screw locks the ear in place.

WARNING

Be careful of high voltages. The lower voltage buses are potentially more dangerous than the crt accelerating voltages because of the higher current capabilities and larger filter capacitors in these supplies. When you reach into the instrument while it is turned on, do not hold the frame with the other hand. If possible, stand on an insulated floor and use insulated tools.

234-Volt Operation

Unless tagged otherwise, this oscilloscope is connected at the factory for 117-volt operation. To connect it for 234-volt operation, remove the jumper between terminals 1 and 2 and the jumper between terminals 3 and 4 on the power transformer. Connect a jumper between terminals 2 and 3. Move the black fan lead, which is connected to the lead coded brown-brown-brown at the ceramic strip behind the power transformer, to the next lead which is coded brown-red-brown. Install the proper size fuse.

TROUBLE SHOOTING

General

This is a complex electronic instrument. There is no simple way of locating troubles. With an understanding of the circuits, you will generally be able to localize the trouble just from front panel observations.

Troubles are usually caused by tube failure. You can frequently correct them by finding the bad tube and replacing it with a good one. However, sometimes a tube burns up resistors or overstresses capacitors when it fails, and in these cases you will also have to find these bad components. Sometimes you can find them by visual inspection. One way to find bad tubes is to try replacing suspected tubes with good ones. If possible, replace all suspected tubes at one time, and if the trouble is helped, return the old ones, one at a time, until the offending one is discovered.

Power Supply

Correct operation of the power supply is necessary for proper operation of most other circuits in the instrument. So an early step to take when you look for troubles is to check the voltages of the power supplies. All the regulated supplies should be within five per cent of their rated values and should remain steady as the line voltage is varied from 105 to 125 volts or 210 to 250 volts.

If the instrument fails to operate at all, including the fan and pilot light, check the source of power and determine that the power-cord plug is securely in place. Then check the fuse at the back of the instrument near the power receptacle.

If the instrument has been operating but has just stopped, it may have overheated and tripped the thermal cutout. The thermal cutout will reset itself when the instrument cools down enough. Possible causes of overheating are fan stoppage, restriction of air circulation or high room temperature. Be sure the air filter is clean.

Deflection System

The cathode-ray-tube display should help in locating the source of trouble. If no spot

is visible check the positioning control settings. Then advance the INTENSITY control to see if there is a glow indicating a spot positioned off the screen. If no spot can be obtained, short the horizontal deflection plates together and the vertical plates together. If no spot is obtained check the high-voltage power supply or the crt.

If the spot is returned to the screen by shorting the deflection plates, check the amplifier concerned.

If a display is obtained on the crt which is abnormal, refer to the Block Diagram. The Block Diagram should help you determine which block the trouble is associated with. Further reference to the detailed diagrams may be helpful after the trouble is localized.

To sum up the most important points in oscilloscope trouble shooting: (1) almost all troubles will be vacuum tubes (2) if in doubt of the source of trouble, check the power supply and (3) use the presentation on the screen to help you localize the trouble.

RECALIBRATION PROCEDURE

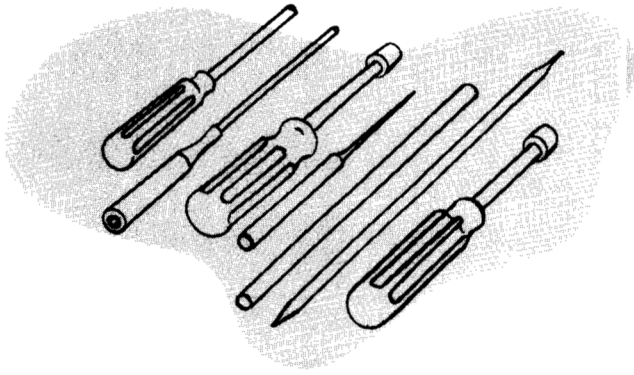

ADJUSTMENT PROCEDURE

General

The following adjustment procedure is based on that used in our own test department. Normally, it will not be necessary to make all of these adjustments at any one time after the original calibration of the instrument. However, any adjustments which are to be made should be made in the sequence given below. For instance the crt-supply voltage should not be set before the -150-volt supply is adjusted as a change in the latter will change the first adjustment. Similarly, the vertical sensitivity should not be set until after the crt-supply voltage is set.

Equipment Required

The following equipment is necessary for a complete calibration of the Type 515/515A Oscilloscope:

(1.) A DC voltmeter having a sensitivity of at least $5000 \Omega/v$ and calibrated for an accuracy of at least 1% at 100, 150 and 300 volts, and an accuracy of at least 3% at 1675 volts. Portable multimeters should be regularly checked against an accurate standard and corrected readings noted, where necessary, at the above listed voltages. **BE SURE YOUR METER IS ACCURATE.**

(2.) An accurate rms-reading ac voltmeter, having a range of 0-150 volts, (0-250 or 0-300 for 234 v. operation.)

(3.) Variable auto-transformer (e.g. Powerstat or Variac) having a rating of at least 6.25 amperes.

(4.) Time-mark Generator, Tektronix Type 180, 180A or equivalent, having markers at 1 μsec , 10 μsec , 50 μsec , 100 μsec , 1 msec,

5 msec, 10 msec, 100 msec, 1 sec, and 5 sec and a sine-wave output of 10 mc, all having an accuracy of at least 1%.

(5.) Square-Wave Generator, Tektronix Type 105 or equivalent, having a risetime of no more than .02 microseconds and a frequency of 1 kc.

(6.) Low-capacitance Recalibration Tools: Tektronix part numbers 003-000, 003-007 and 003-301.

(7.) Tektronix Type P6000 or P410A probe.

(8.) Test Oscilloscope, Tektronix Type 316 or equivalent, providing triggered sweeps and a bandpass of at least dc to 10 mc.

Power Supply

All power-supply voltages except the crt voltages are available at the ceramic strip behind the power transformer. The 10-ohm resistors are ahead of the regulators and the bare wires carry the regulated voltages.

1. -150-Volt Supply Adjustment

The -150-volt supply is the one to which all other supplies are referenced.

- a. Connect an accurate voltmeter to the -150-volt bus.
- b. Adjust the -150 ADJ. control, located behind the delay line, to obtain a reading of -150 volts.

2. CRT-Supply Adjustment

This adjustment determines the total accelerating voltage on the crt and thus affects the deflection sensitivity.

- a. Connect a voltmeter having a resistance of 5000 ohms per volt or higher, from terminals 24 or 25 of the power transformer to ground.
- b. Adjust the -1675 ADJ. control located at the rear of the upper chassis, accessible from the right, to obtain a reading of 1675 volts.

CRT Geometry Adjustment

The GEOM ADJ. control, located in the top row of controls, varies the crt second anode voltage to obtain the best possible linearity near the edge of the graticule.

- a. Set the TIME/CM switch to .5 MILLISEC.
- b. Display the calibrator waveform at a high amplitude so that the top and bottom of the waveform are beyond deflection-plate cutoff.
- c. Adjust the GEOM. ADJ. control so the vertical lines near the edge of the graticule are straight.

Calibrator Adjustment

When the CALIBRATOR switch is turned to OFF, the calibrator cathode follower, V570B, remains conducting at the current required to develop 100 volts across the voltage divider. The CAL. ADJ. control, located just behind the CAL. OUT connector, allows this voltage to be set accurately to 100 volts. Be careful to use an accurate meter as the accuracy of the calibrator can be better than 3 per cent if accurately set.

- a. Turn the calibrator control to OFF.
- b. Connect the meter from ground to the pin jack labeled CAL. TEST POINT, located behind the CALIBRATOR switch.
- c. Adjust the CAL. ADJ. control for 100 volts.

Vertical-Amplifier Adjustment

1. DC Balance Adjustment

The need for adjustment of the DC BAL control is indicated by a shift in the position of the trace as the VARIABLE control is

rotated. This is caused by tube aging and the resultant shift in operating potentials.

- a. Rotate the VARIABLE VOLTS/CM control back and forth.
- b. Adjust the DC BAL. control until the trace position is no longer affected by rotation of the VARIABLE control.

2. Gain Adjustment

Aging of tubes will also affect the gain of the amplifier. The GAIN ADJ. control is accessible from the top side of the lower chassis just in front of the vertical delay-line section. This control allows the amplifier gain to be set to agree with the front-panel calibration.

- a. Set the VOLTS/CM controls to .05, CALIBRATED. (.1, CALIBRATED, Serial Numbers 101-1000).
- b. Display a calibrated waveform of .2 volts. (.5 volts Serial Numbers 101-1000).
- c. Adjust the GAIN ADJ. control until the displayed waveform is four graticule divisions high.

Attenuator Adjustments

The need for adjustment of the input attenuators is determined by observing the response to a 1-kc square wave. There are two types of adjustment to be made. One is to compensate the attenuators so the ac attenuation is equal to the dc attenuation. This involves a moderately short time constant and can be recognized as a slight rounding or overshoot at the leading corner of a 1-kc square wave. The other type of adjustment is to set the input capacitance equal in all positions of the attenuator. When the probe is connected, misadjustment can be recognized as a downward or upward slope of about the first one-half of the 1-kc square wave.

For best results, the attenuator adjustment should be made with a square-wave generator having a short risetime, such as the Tektronix Type 105. An approximate adjustment can be made by using the calibrator waveform, but it is easy to overcompensate the attenuator when using this waveform because of its longer risetime.

1. Attenuator Compensation

The attenuator is compensated to make the ac attenuation equal to the dc attenuation.

- a. Connect the square-wave generator to INPUT 1.
- b. Set the square-wave generator to 1 kc and view five or six cycles on the screen.
- c. Set the VOLTS/CM switch to the positions indicated and adjust each capacitor in the following table for a square corner on the square wave. The capacitors are identified by numbers on the chassis just above the attenuator switch.

VOLTS/CM	CAPACITOR
.1	C306
.2	C312
.5	C316
5	C320

(Serial Number 101-1000)

VOLTS/CM	CAPACITOR
.2	C306
.5	C312
1	C316
10	C320

2. Input-Capacitance and Probe Adjustment

The probe is used to set the input capacitance of all the attenuator positions to the same value.

- a. Connect the probe to INPUT 1.
- b. Connect the output of the square-wave generator to the probe.
- c. Set the VOLTS/CM switch to the positions indicated and adjust each capacitor in the following table for a flat top on the square wave.

VOLTS/CM	CAPACITOR
.05	Probe Trimmer
.1	C305
.2	C311
.5	C315
5	C319

(Serial Number 101-1000)

VOLTS/CM	CAPACITOR
.1	Probe Trimmer
.2	C305
.5	C311
1	C315
10	C319

High-Frequency Compensation

The vertical-amplifier high-frequency compensation is adjusted by means of six inductors and the delay-line trimmers. These adjustments should be quite stable. Minor adjustments may be required as tubes are changed, however.

A square-wave generator having a risetime of 12 millimicroseconds or better should be used when making these adjustments. The Tektronix Type 107 is recommended. The Tektronix Type 105 is satisfactory if precautions are taken to obtain the best risetime possible. Refer to the instruction manual for these instruments for information on the proper termination of the interconnecting coaxial cable.

- a. Connect the output of the square-wave generator to INPUT 1.
- b. Set the square-wave generator to 250 kc.
- c. Set the VOLTS/CM switch to .05, CALIBRATED (.2, CALIBRATED Serial Number 101-1000).
- d. Set the square-wave generator amplitude for about 4-cm of deflection.
- e. Set the TIME/CM switch to .5 μ SEC/CM.
- f. Set the TRIGGER SELECTOR controls to AC, -INT. and display the square wave. Misadjustment of the coils or trimmers will be indicated by spikes or wrinkles starting at the top corner of the square wave and extending for .5 microseconds along the square wave. Disregard the bottom of the square wave.
- g. Start with C486 and C485 located near the neck of the crt and work toward the front of the delay line, removing any wrinkles which are present. Adjust L485 and L486 in sequence, leaving them

balanced with the core in about the same position in each coil. Reduce the sweep speed occasionally to check the level of the first one-half microsecond of the square wave.

- h. Absence of the cabinet panel causes a misadjustment of the first five delay-line trimmers. After the delay line has been adjusted, place a small piece of aluminum, about 4" x 8", at the front-left side where the cabinet panel would normally be. This will cause a slight wrinkle near the top left corner of the square wave. Readjust the first five trimmers, C440-C444, to remove the wrinkle. If desired, a special shield is available from the factory to provide the necessary shielding. This shield may be ordered by specifying part number 333-362.
- i. Adjust L391 and L401 for a sharp corner without overshoot.
- j. Adjust L351 and L361. These coils affect the corner and leading edge of the square wave. Be careful to leave the two coils balanced. If you are using a Type 105 square-wave generator set these coils where a spike is not even beginning to show. Otherwise a faster pulse will show an overshoot.

Trigger-Circuit Adjustments

1. Triggering Level Centering

The TRIGGERING LEVEL CENTERING control is located in the top row of controls. This control sets the level of the trigger-shaper stage so that no readjustment of the TRIGGERING LEVEL control is required as the TRIGGER SELECTOR switch is changed from + to - slope.

- a. Set the TRIGGER SELECTOR switches to +INT, AC.
- b. Display the calibrator waveform with 2 to 4 mm deflection.
- c. Turn the black TRIGGER SELECTOR knob back and forth from +INT to -INT. Simultaneously adjust the TRIGGERING LEVEL CENTERING control and the TRIGGERING

LEVEL control until no change of either control is required as the black TRIGGER SELECTOR knob is changed from +INT to -INT.

2. Internal Trigger DC Level

The INT. TRIG. DC LEVEL ADJ. control, R3, sets the triggering level in the DC position of the red TRIGGER SELECTOR knob. It is set so the sweep will trigger near 0 on the TRIGGERING LEVEL control when the trace is centered vertically.

- a. Display the calibrator waveform with 1 cm of deflection and the trace centered.
- b. Turn the red TRIGGER SELECTOR knob to DC.
- c. Turn the TRIGGERING LEVEL control to 0.
- d. Adjust the INT. TRIG. DC LEVEL ADJ. control, located near the front of the top chassis, so the sweep will trigger on either + or -INT without readjustment of the TRIGGERING LEVEL control.

3. Trigger Sensitivity (SN 101-1000)

The Trig. Sensitivity control, located in the top row of controls, adjusts the sensitivity of the trigger-shaper stage. If the sweep triggers erratically or on the wrong slope it may indicate that this adjustment is incorrect.

- a. Remove the vertical signal.
- b. Turn the TRIGGER SLOPE switch to +LINE.
- c. Set the sweep controls to 100 μ SEC/CM and trigger from the line.
- d. Turn the Trig. Sens. control clockwise until the trace brightens abruptly. This indicates that the trigger circuit is oscillating. Now back the control off about 45 degrees.

4. Stability Preset Adjustment (SN 1001-up)

The Preset Stability control sets the stability of the main sweep trigger circuit in the AUTO position of the red TRIGGER SELECTOR knob

and in the PRESET position of the STABILITY control. It is adjusted so that the free-running trigger multivibrator will trigger the main sweep multivibrator, but will not allow the main sweep multivibrator to free-run.

- a. Turn the red TRIGGER SELECTOR knob to AUTO.
- b. Disconnect any signal source that may be connected to the INPUT connector.
- c. Advance the Preset Stability adjustment until a trace appears on the crt. Note the position of the screwdriver slot.
- d. Advance the Preset Stability adjustment further until the trace brightens. Note the position of the screwdriver slot.
- e. Retard the Preset Stability adjustment to a point midway between the positions found in parts 3-c and 3-d.

Time-Base Circuit Adjustments

The time-base circuits of the Type 515/515A are quite stable and should not require frequently readjustments. The need for readjustment can be determined quickly by checking the time-base calibration with an accurate time-mark generator. Often only a single adjustment need be made.

We check our time base with a Tektronix Type 180A or 181 Time-Mark Generator. However, you can use any other frequency generator accurate to one per cent or better. Because the small amount of non-linearity present in the time base is concentrated in the first and last centimeters, we adjust the timing over the center 8 centimeters of the display. In this way the errors are minimized and the accuracy over the center portion can approach a value limited principally by the spot size.

The following procedure is based on that used in our test department. This sequence should be followed.

1. Magnifier Timing Adjustment

The Mag. Gain Adj. control, R259, adjusts the gain of the horizontal amplifier to calibrate the time-base ranges with the magnifier on.

- a. Set the TIME/CM controls to 1 MILLISEC, CALIBRATED. (VARIABLE clockwise.)
- b. Display 100-microsecond markers.
- c. Center the trace with the HORIZONTAL POSITIONING control.
- d. Set the HORIZ. DISPLAY switch to MAG.
- e. Adjust the Mag. Gain Adj. control, located over the neck of the crt, so that every second marker corresponds with a graticule line.

2. Normal-Sweep Timing Adjustment

The Horiz. Gain Adj. control, R225, adjusts the amount of feedback in the horizontal amplifier to calibrate the time-base ranges in the NORM. position of the HORIZ. DISPLAY switch.

- a. Display 1-millisecond markers with the TIME/CM controls set at 1 MILLISEC, CALIBRATED.
- b. Set the HORIZ. DISPLAY switch to NORM.
- c. Adjust the Horiz. Gain Adj. control, located on the HORIZ. DISPLAY switch just above the power transformer, so the markers correspond with the graticule.

3. Sawtooth Amplitude Adjustment

The Sawtooth Amplitude control, located in the top row of controls, provides a means of setting the sweep length so it fills the graticule without hitting the sides of the crt attendant electron scattering.

- a. Set the Sawtooth Amplitude control so the sweep is about 10 1/2 centimeters long.

4. Mag Registration

The Mag. Regis. control, located in the top row of controls, adjusts the voltage on the feed-back network so the magnifier expands the trace both ways from screen center.

- a. Back the STABILITY control off to stop the sweep.
- b. Turn up the INTENSITY control so the spot is visible.

- c. Turn the HORIZ. DISPLAY switch to MAG. and position the spot behind the center graticule line with the HORIZONTAL POSITIONING control.
- d. Turn the HORIZ. DISPLAY switch to NORM. and adjust the Mag. Regis. control so that the spot is again centered.

5. 10-Microsec/cm Adjustment

A trimmer, C160E, across the timing capacitor, adjusts the rate of the sweep in the 10-, 20-, and 50- μ SEC/CM positions of the TIME/CM switch.

- a. Set the TIME/CM controls to 10 μ SEC/CM, CALIBRATED.
- b. Display 10-microsecond markers.
- c. Adjust C160E, the top trimmer on the TIME/CM switch, so the markers correspond with the graticule.

6. 1-Microsec/cm Adjustment

Capacitor C160C adjusts the rate of the 1-, 2- and 5-microsecond/cm sweeps.

- a. Set the TIME/CM controls to 5 μ SEC/CM, CALIBRATED.
- b. Display 1-microsecond markers.
- c. Turn the HORIZ. DISPLAY switch to MAG.
- d. Position the trace to the left so the end of the trace is visible and adjust C160C, located on the TIME/CM switch, so the markers correspond with the graticule.

7. 1-Microsec/cm Linearity Adjustment

Capacitor C210 affects the rate of the start of the trace in the high-speed ranges.

- a. With the controls unchanged from step 6, position the trace to the right so the start of the trace is visible.
- b. Adjust C210, located just to the rear of the top row of controls, so the markers correspond with the graticule.
- c. Recheck step 6-d.

8. 2-Microsec/cm Linearity Adjustment

Capacitor C224 compensates the divider in the feedback network and affects the start of the trace in the NORM. position of the HORIZ. DISPLAY switch.

- a. Set the TIME/CM controls to 2 μ SEC/CM, CALIBRATED.
- b. Set the HORIZ. DISPLAY switch to NORM.
- c. Display 1-microsecond markers.
- d. Adjust C224 so the sweep rate over the first two centimeters is the same as for the remainder of the trace. C224 is located on the HORIZ. DISPLAY switch just above the power transformer.

9. .5-Microsec/cm Adjustment

Trimmer C160A serves as the timing capacitor in the .2- and .5-microsec/cm ranges.

- a. Set the TIME/CM controls to .5 μ SEC/CM, CALIBRATED.
- b. Display 1-microsecond markers.
- c. Adjust C160A, located near the bottom of the TIME/CM switch, so that a marker corresponds with every second graticule line.

10. .2-Microsec/cm Linearity Adjustment

Capacitor C260 provides high-frequency compensation to obtain a linear sweep at this rate.

- a. Set the TIME/CM controls to .2 μ SEC/CM, CALIBRATED.
- b. Display a 10-mc sine wave.
- c. Adjust C260, located on the plastic plate over the neck of the crt, for two cycles for each cm. This adjustment has the greatest effect over the first five centimeters.

11. .04-Microsec/cm Adjustment

Capacitor C272, located behind the plastic plate over the neck of the crt, adjusts the maximum sweep speed of the oscilloscope.

- a. Set the TIME/CM controls to $.2 \mu\text{SEC}/\text{CM}$, CALIBRATED.
- b. Display a 10-mc sine wave with the trace centered.
- c. Turn the HORIZ. DISPLAY switch to MAG. Do not change the HORIZONTAL POSITIONING control.
- d. Adjust C272 so there are four cycles in ten centimeters.
- e. Recheck step 10.

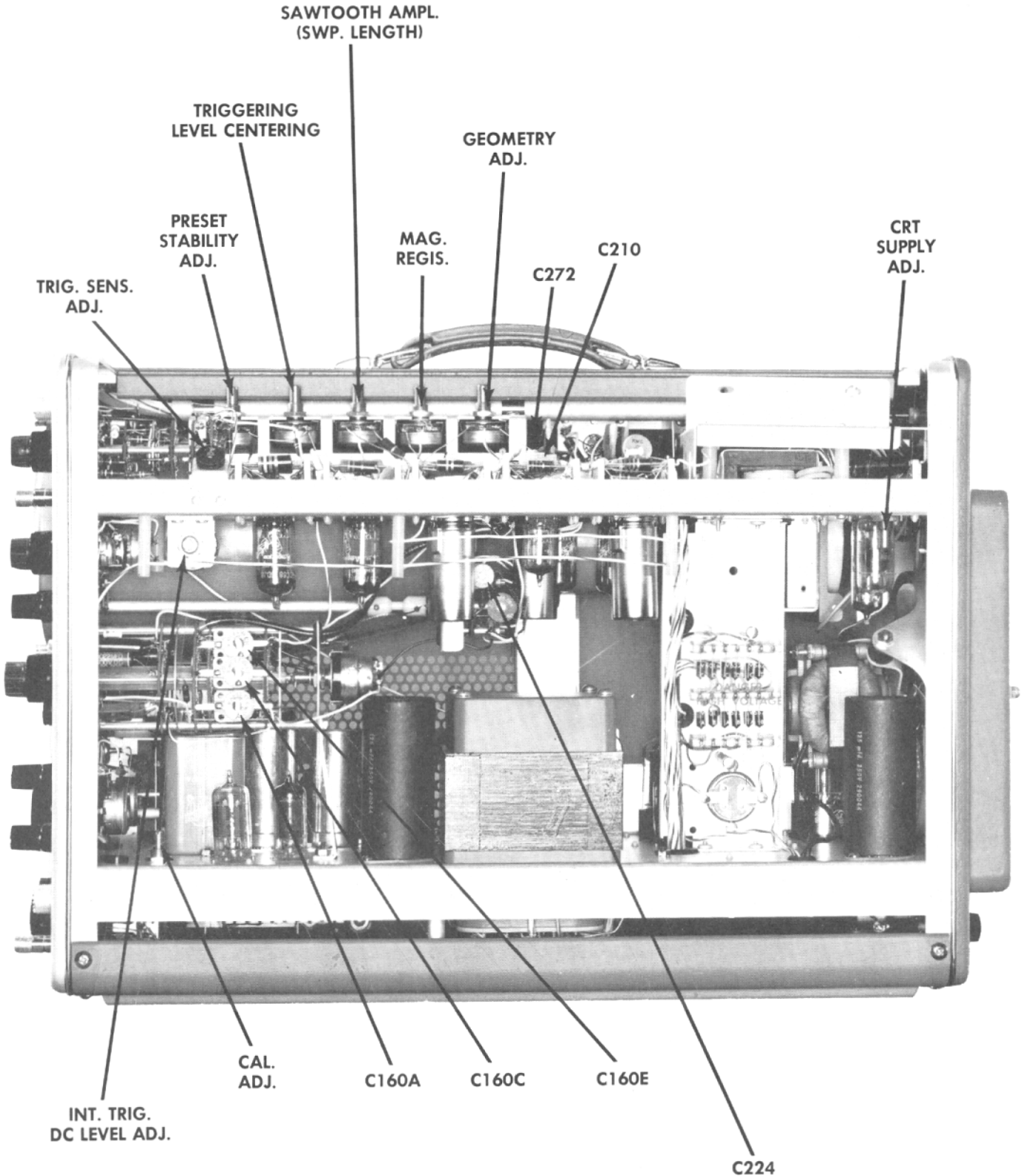

Fig. 5-1 Right Side View

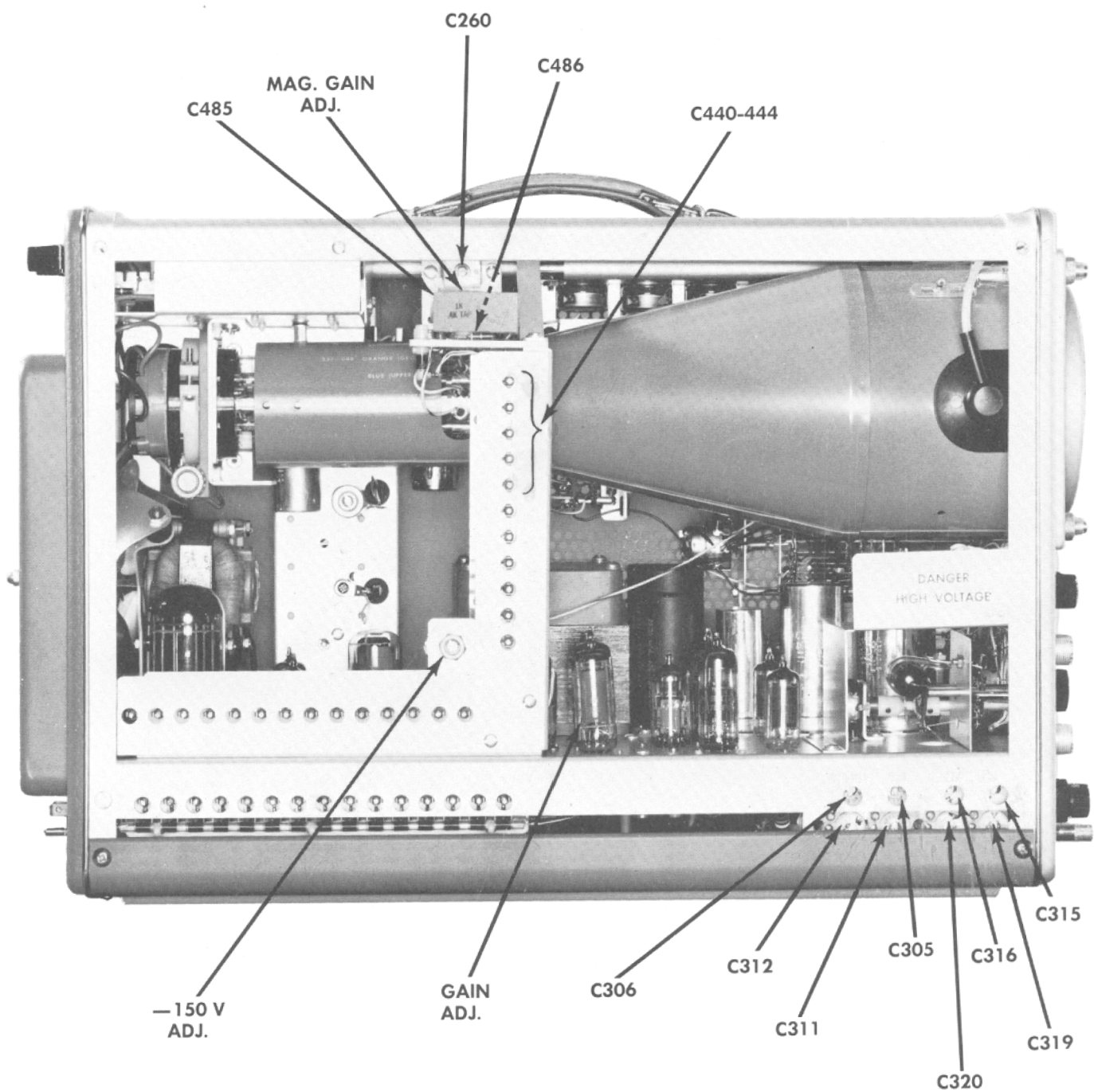

Fig. 5-2 Left Side View

PARTS LIST *and*

DIAGRAMS

(Faint, illegible text from a parts list or diagram is visible in the background of this page.)

Cer.
Comp.
EMC
f
G
GMV
h
K or k
M/Cer.
M or meg
μ
/M
m

ABBREVIATIONS

n	Nano or 10 ⁻⁹
Ω	ohm
p	Pico or 10 ⁻¹²
PTB	Paper, "Bathtub"
PMC	Paper, metal cased
Poly.	Polystyrene
Prec.	Precision
PT	Paper Tubular
T	Terra or 10 ¹²
v	Working volts DC
Var.	Variable
w	Watt
WW	Wire-wound

Ceramic
Composition
Electrolytic, metal cased
Farad
Giga, or 10⁹
Guaranteed minimum value
Henry
Kilohms or kilo (10³)
Mica or Ceramic
Megohms or mega (10⁶)
Micro, or 10⁻⁶
Micromicro or 10⁻¹²
milli or 10⁻³

SPECIAL NOTES AND SYMBOLS

+ and up

† Approximate serial number.

X000 Part first added at this serial number.

000X Part removed after this serial number.

* 000-000 Asterisk preceding Tektronix Part Number indicates manufactured by or for Tektronix, also reworked or checked components.

(Mod. w/) Simple replacement not recommended.

Modify to value for later instruments and change other parts to match.



MANUFACTURERS OF CATHODE-RAY OSCILLOSCOPES

HOW TO ORDER PARTS

Replacement parts are available through your local Tektronix Field Office.

Improvements in Tektronix instruments are incorporated as soon as available. Therefore, when ordering a replacement part it is important to supply the part number including any suffix, instrument type, serial number, plus a modification number where applicable.

If the part you have ordered has been improved or replaced, your local Field Office will contact you if there is a change in part number.

TYPE 515A
Mod. 3856
Tent. S/N 6980

The instrument has been modified by changing to a lighter fan.
The purpose is to minimize breaking of 6080 tubes during shipment.

PARTS LIST

Fan motor	Change to	147-022
C603 Add	2 μ f 236v - PMC	285-588

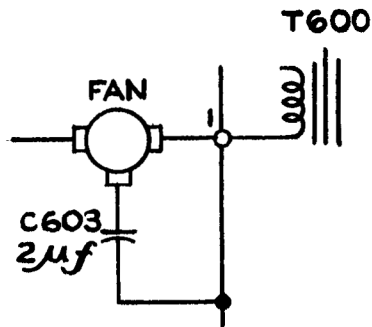

PART. DIAG. PWR. SPLY

11-30-61

PARTS LIST

Type 515, SN's 101-1000; Type 515A, SN1001-up

Bulbs

			Tektronix Part Number
B152		Neon, NE-2	150-002
B160	101-904 905-up	Neon, NE-2, Checked 55 v drop Neon, NE-2	*150-009 150-002
B161	101-904 905-up	Neon, NE-2, Checked 60 v drop Neon, NE-2	*150-010 150-002
B222	X1001-up	Neon, NE-2	150-002
B253		Neon, NE-2	150-002
B280		Neon, NE-2	150-002
B357		Neon, NE-2	150-002
B373	X1001-1613X	Neon, NE-2	150-002
B383	X1001-1613X	Neon, NE-2	150-002
B410		Neon, NE-2	150-002
B416		Neon, NE-2	150-002
B600		Incandescent, #47	150-001
B601		Incandescent, #47	150-001
B602		Incandescent, #47	150-001

Capacitors

Values fixed unless marked Variable

Tolerance $\pm 20\%$ unless otherwise indicated.

C3		4.7 $\mu\mu\text{f}$	Cer.		500 v	$\pm 1 \mu\mu\text{f}$	281-501
C4		.01 μf	PT		400 v		285-510
C9		.001 μf	Cer.		500 v	GMV	283-000
C12		.001 μf	Cer.		500 v	GMV	283-000
C15	X4804-5308 5309-up	10 $\mu\mu\text{f}$ 100 $\mu\mu\text{f}$	Cer. Cer.		500 v 350 v	$\pm 1 \mu\mu\text{f}$	281-504 281-523
C20		.01 μf	Cer.		150 v	GMV	283-003
C21		.01 μf	Cer.		500 v	GMV	283-002
C28	101-547X X4804-up	.005 μf .005 μf	Cer. Cer.		500 v 500 v	GMV GMV	283-001 283-001
C38		18 $\mu\mu\text{f}$	Cer.		500 v	10%	281-542
C109		27 $\mu\mu\text{f}$	Cer.		500 v		281-513
C111		8 $\mu\mu\text{f}$	Cer.		500 v	10%	281-503
C114		.01 μf	Cer.		500 v	GMV	283-002
C115		5.6 $\mu\mu\text{f}$	Cer.		500 v	10%	281-544
C120		12 $\mu\mu\text{f}$	Cer.		500 v	5%	281-508
C127		56 $\mu\mu\text{f}$	Cer.		500 v	10%	281-521
C160A		3-12 $\mu\mu\text{f}$	Cer.	Var.	500 v		281-007
C160B		82 $\mu\mu\text{f}$	Mica		500 v	5%	283-534
C160C	101-1000 1001-up	5-20 $\mu\mu\text{f}$ 4.5-25 $\mu\mu\text{f}$	Cer. Cer.	Var. Var.	500 v 500 v		Use 281-010 281-010
C160D		82 $\mu\mu\text{f}$	Mica		500 v	5%	283-534
C160E	101-1000 1001-up	5-20 $\mu\mu\text{f}$ 4.5-25 $\mu\mu\text{f}$	Cer. Cer.	Var. Var.	500 v 500 v		Use 281-010 281-010

Capacitors (continued)

							Tektronix Part Number
C160F		.001 μ f		Mylar		$\pm 1/2\%$	*291-008
C160G		.01 μ f	}	Mylar Timing Series		$\pm 1/2\%$	*291-007
C160H		.1 μ f					
C160J		1 μ f					
C161		.001 μ f			Cer.		
C165		470 μ μ f	Cer.	500 v			281-525
C180A		180 μ μ f	Mica	500 v	10%		283-509
C180B		.0022 μ f	PT	400 v			285-543
C180C		.022 μ f	PT	400 v			285-515
C180D		.1 μ f	PT	400 v			285-526
C180E		.1 μ f	PT	400 v			285-526
C181		39 μ μ f	Cer.	500 v	10%		281-516
C184		.001 μ f	Cer.	500 v	GMV		283-000
C210	101-870	5-20 μ μ f	Cer.	Var.	500 v		Use 281-010
	871-up	4.5-25 μ μ f	Cer.	Var.	500 v		281-010
C215		15 μ μ f	Cer.		500 v	10%	281-509
C224		3-12 μ μ f	Cer.	Var.	500 v		281-009
C233		1.5 μ μ f	Cer.		500 v	$\pm 1/2 \mu$ μ f	281-526
C246		6.8 μ f	Cer.		500 v	10%	281-541
C260		9-180 μ μ f	Cer.	Var.	500 v		281-023
C267		.01 μ f	Cer.		500 v	GMV	283-002
C272		3-12 μ μ f	Cer.	Var.	500 v		281-009
C301		.1 μ f	PT		600 v		285-528
C305		1.5-7 μ μ f	Cer.	Var.	500 v		281-005
C306	101-1000	5-20 μ μ f	Cer.	Var.	500 v		Use 281-010
	1001-up	4.5-25 μ μ f	Cer.	Var.	500 v		281-010
C311		3-12 μ μ f	Cer.	Var.	500 v		281-007
C312		3-12 μ μ f	Cer.	Var.	500 v		281-007
C315		3-12 μ μ f	Cer.	Var.	500 v		281-007
C316		3-12 μ μ f	Cer.	Var.	500 v		281-007
C317		47 μ μ f	Cer.		500 v	10%	281-519
C319	101-1000	5-20 μ μ f	Cer.	Var.	500 v		Use 281-010
	1001-up	4.5-25 μ μ f	Cer.	Var.	500 v		281-010
C320		1.5-7 μ μ f	Cer.	Var.	500 v		281-005
C321		250 μ μ f	Mica		500 v	5%	283-543
C326		100 μ μ f	Cer.		350 v		281-523
C330		.01 μ f	Cer.		500 v	GMV	283-002
C332		.01 μ f	Cer.		500 v	GMV	283-002
C334		.01 μ f	Cer.		500 v	GMV	283-002
C335	101-1613	.001 μ f	Cer.		500 v	GMV	283-000
	1614-up	.01 μ f	Cer.		500 v	GMV	283-002
C342		.01 μ f	Cer.		500 v	GMV	283-002
C352		20 μ f	EMC		150 v	-10+100%	290-008
C355	X1614-up	5.6 μ μ f	Cer.		500 v	10%	281-544
C359	X1001-1613X	.01 μ f	Cer.		500 v	GMV	283-002
C362		20 μ f	EMC		150 v	-10+100%	290-008
C376	X1614-up	.005 μ f	Cer.		500 v		283-001
C393		.001 μ f	Cer.		500 v	GMV	283-000
C401	X5080-5849	3.3 μ μ f	Cer.		500 v	$\pm 25 \mu$ μ f	281-534
	5850-up	1.5 μ μ f	Cer.		500 v	$\pm 25 \mu$ μ f	281-529
C403		.001 μ f	Cer.		500 v	GMV	283-000

Capacitors (continued)

Tektronix
Part Number

C412		.01 μ f	Cer.		500 v	GMV	283-002
C440-C479		.7-3 μ μ f	Tub.	Var.	500 v		281-027
C485		.7-3 μ μ f	Tub.	Var.	500 v		281-027
C486		3-12 μ μ f	Cer.	Var.	500 v		281-031
C490		.01 μ f	Cer.		500 v	GMV	283-002
C552		330 μ μ f	Mica		500 v	10%	283-518
C554		330 μ μ f	Mica		500 v	10%	283-518
C570		27 μ μ f	Cer.		500 v		281-513
C601		125 μ f	EMC		350 v	-10+100%	290-044
C602		.01 μ f	PT		400 v		285-510
C603	101-6980X	2 μ f	PMC		236 v		285-588
C613		.01 μ f	PT		400 v		285-510
C621		2 x 20 μ f	EMC		450 v	-10+50%	290-036
C630		125 μ f	EMC		350 v	-10+100%	290-052
C631		125 μ f	EMC		350 v	-10+100%	290-052
C636		.01 μ f	PT		400 v		285-510
C639A,B		2 x 20 μ f	EMC		450 v	-10+50%	290-037
C645		.01 μ f	Cer.		500 v	GMV	283-002
C650	101-1326	.001 μ f	Cer.		500 v	GMV	283-000
	1327-1613	.01 μ f	Cer.		150 v	GMV	283-003
	1614-up	.01 μ f	Cer.		500 v	GMV	283-002
C660		125 μ f	EMC		350 v	-10+100%	290-044
C661		125 μ f	EMC		350 v	-10+100%	290-044
C666		.01 μ f	PT		400 v		285-510
C703		.001 μ f	PT		600 v		285-501
C706		.001 μ f	PT		1000 v		285-502
C707		.001 μ f	PT		1000 v		285-502
C708A,B		2 x 20 μ f	EMC		450 v	-10+50%	290-037
C714		.022 μ f	PT		400 v		285-515
C720	101-5189	.0068 μ f	PT		3000 v		285-508
	5190-6369	.01 μ f	Cer.		2000 v		283-011
	6370-up	.0068 μ f	Cer.		3000 v	GMV	283-043
C721	101-5189	.0068 μ f	PT		3000 v		285-508
	5190-6369	.005 μ f	Cer.		4000 v		283-034
	6370-up	.0068 μ f	Cer.		3000 v	GMV	283-043
C722	101-5189	.0068 μ f	PT		3000 v		285-508
	5190-6369	.01 μ f	Cer.		2000 v		283-011
	6370-up	.0068 μ f	Cer.		3000 v	GMV	283-043
C732	101-4679	.015 μ f	PT		3000 v		285-513
	4680-6369	.01 μ f	Cer.		2000 v		283-011
	6370-up	.015 μ f	Cer.		3000 v		283-042
C734	101-4679	.015 μ f	PT		3000 v		285-513
	4680-6369	.01 μ f	Cer.		2000 v		283-011
	6370-up	.015 μ f	Cer.		3000 v		283-042
C735	X5190-6369	.01 μ f	Cer.		2000 v		283-011
	6370-up	.015 μ f	Cer.		3000 v		283-042
C743	101-6130	.001 μ f	PT		3000 v		Use 283-021
	6131-6369	.001 μ f	Cer.		5000 v		283-021
	6370-up	.001 μ f	Cer.		3000 v		283-044
C745	101-5189	.0068 μ f	PT		3000 v		285-508
	5190-6369	.01 μ f	Cer.		2000 v		283-011
	6370-up	.0068 μ f	Cer.		3000 v	GMV	283-043
C748	101-4679	.015 μ f	PT		3000 v		285-513
	4680-6369	.01 μ f	Cer.		2000 v		283-011
	6370-up	.015 μ f	Cer.		3000 v		283-042
C750		.01 μ f	Cer.		500 v	GMV	283-002
C754	X245-up	.01 μ f	Cer.		500 v	GMV	283-002

Diodes

Tektronix
Part Number

*Even though the diodes may be different in physical size, they are direct electrical replacements for the diodes in your instrument.

D130	X4804-up	T12-G Germanium Diode	152-008
D601 A,B,C,D	X4030-up	Silicon Diode	152-047
D632 A,B,C,D	X4030-up	Silicon Diode	152-047
D662 A,B,C,D	X4030-up	Silicon Diode	152-047

Fuses

F601	3 amp 3 AG Slo-Blo 117 V operation	159-005
	1.6 amp 3 AG Slo-Blo 234 V operation	159-003

Inductors

L350	X1001-up	1.2 μ h	Fixed	*108-056
L351	101-1000	5.2-8.3 μ h	Var.	*114-056
	1001-up	6.8-14.6 μ h	Var.	*114-080
L361	101-1000	5.2-8.3 μ h	Var.	*114-056
	1001-up	6.8-14.6 μ h	Var.	*114-080
L390	101-1000	1.2 μ h	Fixed	*108-056
	1001-up	1.8 μ h	Fixed	*108-105
L391	101-1613	3.6-8.3 μ h	Var.	*114-055
	1614-5079	7 μ h	Fixed	*108-137
	5080-up	7-13.5 μ h	Var.	*114-132
L400	101-1000	1.2 μ h	Fixed	*108-056
	1001-up	1.8 μ h	Fixed	*108-105
L401	101-1613	3.6-8.3 μ h	Var.	*114-055
	1614-5079	7 μ h	Fixed	*108-138
	5080-up	7-13.5 μ h	Var.	*114-132
LR363	101-1000	6 μ h	Fixed	*108-114
	1001-1162	8.8 μ h	Fixed	Use *108-114
	1163-up	6 μ h	Fixed	*108-114
L440		Delay Line 15-section		*108-108
L441		Delay Line 15-section		*108-108
L453	101-2182	2.5 μ h	Fixed	*108-103
	2183-up	2.2 μ h	Fixed	*108-147
L454	101-2182	2.5 μ h	Fixed	*108-103
	2183-up	2.2 μ h	Fixed	*108-147
L455		Delay Line 14-section		*108-107
L456		Delay Line 14-section		*108-107
L470		Delay Line 11-section		*108-106
L471		Delay Line 11-section		*108-106
L485		7.3-16 μ h	Var.	*114-054
L486		7.3-16 μ h	Var.	*114-054

Resistors

Resistors are fixed, composition, $\pm 10\%$ unless otherwise indicated.

R2	100 k	$\frac{1}{2}$ w					302-104
R3	50 k	2 w	Var.	Comp.	Int. Trig.	DC Level Adj.	311-023
R4	1 meg	$\frac{1}{2}$ w	Fixed	Comp.	5%		301-105

Resistors (continued)

							Tektronix Part Number
R5		560 k	1/2 w	Fixed	Comp.	5%	301-564
R8		1 meg	1/2 w				302-105
R9		470 k	1/2 w				302-474
R10		100 Ω	1/2 w				302-101
R11	101-4803	5.6 k	1/2 w				302-562
	4804-up	3.9 k	1/2 w				302-392
R12		27 Ω	1/2 w				302-270
R13	X4804-up	39 k	2 w				306-393
R14	101-4803	20 k	8 w	Fixed	WW	5%	308-081
	4804-up	39 k	2 w				306-393
R15	X4804-up	3.9 k	1/2 w				302-392
R16		100 Ω	1/2 w				302-101
R19		100 k	1/2 w				302-104
R20		100 Ω	1/2 w				302-101
R21		100 k	1/2 w				302-104
R22		220 k	1/2 w				302-224
R23		3.9 meg	1/2 w				302-395
R24		820 k	1/2 w				302-824
R25		1 meg	1/2 w				302-105
R26	101-870†	100 k	1/2 w	Var.	Comp.	TRIG. LEVEL	311-087
	871-up††	100 k	1/2 w	Var.	Comp.	TRIG. LEVEL	311-099
R27	101-547	22 k	1 w				304-223
	548-4803	11 k	2 w	Fixed	Comp.	5%	305-113
	4804-up	22 k	1 w				304-223
R28	101-547X	500 Ω	2 w	Var.	Comp.	Trig. Sens.	311-005
	X4804-5308	330 Ω	1/2 w				302-331
	5309-up	500 Ω	.1 w	Var.	Comp.	Trig. Sens.	311-056
R29	101-547X	22 k	1 w				304-223
R30	X4804-up	22 k	1 w				304-223
R31	101-547	3.3 k	1/2 w				302-332
	548-4803	3.3 k	1/2 w	Fixed	Comp.	5%	301-332
	4804-6369	2.2 k	1/2 w				Use 301-222
	6370-up	2.2 k	1/2 w	Fixed	Comp.	5%	301-222
R32		1 k	1/2 w				302-102
R35		100 Ω	1/2 w				302-101
R36		820 Ω	1/2 w				302-821
R38		150 k	1/2 w				302-154
R39		120 k	1/2 w				302-124
R40		100 k	2 w	Var.	Comp.	Trig. Level Cent.	311-026
R42	X2144-up	1 meg	1/2 w				302-105
R45		2.2 meg	1/2 w				302-225
R109		100 Ω	1/2 w				302-101
R111		3.6 k	1 w	Fixed	Comp.	5%	303-362
R112		3.6 k	1 w	Fixed	Comp.	5%	303-362
R113		100 Ω	1/2 w				302-101
R114		100 Ω	1/2 w				302-101
R115		43 k	1 w	Fixed	Comp.	5%	303-433
R116		33 k	1 w	Fixed	Comp.	5%	303-333
R117		10 k	5 w	Fixed	WW	5%	308-054
R118		47 Ω	1/2 w				302-470
R119		47 Ω	1/2 w				302-470
R120		18 k	1 w			5%	Use 303-183

† R26 concentric with R145 and R230. Furnished as a unit.

†† Furnished as a unit with R145, R230 and SW145.

Resistors (continued)

							Tektronix Part Number
R121		33 k	2 w			5%	Use 305-333
R122		10 k	1/2 w				302-103
R124		47 Ω	1/2 w				302-470
R125	101-3417	680 Ω	1/2 w				Use 302-102
	3418-up	1 k	1/2 w				302-102
R126		150 k	1 w				304-154
R127		680 Ω	1/2 w				302-681
R140		100 Ω	1/2 w				302-101
R141		27 k	1/2 w	Fixed	Comp.	5%	301-273
R142		39 k	1/2 w	Fixed	Comp.	5%	301-393
R143		4.7 k	1/2 w				302-472
R144		100 k	1/2 w				302-104
R145	101-870†	500 k	1/2 w	Var.	Comp.	STABILITY	311-087
	871-up††	500 k	1/2 w	Var.	Comp.	STABILITY	311-099
R146	X630-up	100 k	2 w	Var.	Comp.	Preset Stab.	311-026
R151	X4860-up	1 meg	1/2 w				302-105
R152		100 k	1/2 w				302-104
R153	101-357	10 k	1/2 w				Use 302-822
	358-up	8.2 k	1/2 w				302-822
R154	101-2427	20 k	2 w	Var.	Comp.	VARIABLE	311-883
	2428-up	20 k	2 w	Var.	Comp.	VARIABLE	311-108
R155		10 k	5 w	Fixed	WW	5%	308-054
R156		2 k	2 w	Var.	Comp.	SWP. Length	311-008
R157		2.2 k	1 w				304-222
R158		6 k	5 w	Fixed	WW	5%	308-052
R159		100 Ω	1/2 w				302-101
R160		100 Ω	1/2 w				302-101
R160A		100 k	1/2 w	Fixed	Prec.	1%	309-045
R160B		200 k	1/2 w	Fixed	Prec.	1%	309-051
R160C		500 k	1/2 w	Fixed	Prec.	1%	309-003
R160D		1 meg	1/2 w	Fixed	Prec.	1%	309-014
R160E		2 meg	1/2 w	Fixed	Prec.	1%	309-023
R160F		5 meg	1/2 w	Fixed	Prec.	1%	309-087
R160G		10 meg	1/2 w	Fixed	Prec.	1%	309-095
R160H		10 meg	1/2 w	Fixed	Prec.	1%	309-095
R160J		10 meg	1/2 w	Fixed	Prec.	1%	309-095
R161	101-904	47 k	1/2 w				Use 302-474
	905-up	470 k	1/2 w				302-474
R162		1.5 meg	1/2 w				302-155
R164		47 k	1 w				304-473
R165		47 k	1 w				304-473
R180A		470 k	1/2 w				302-474
R180B		4.7 meg	1/2 w				302-475
R181		4.7 meg	1/2 w				302-475
R182		100 k	1/2 w				302-104
R183		47 Ω	1/2 w				302-470
R184		100 k	1/2 w				302-104
R185		47 Ω	1/2 w				302-470
R210		1.84 meg	1/2 w	Fixed	Prec.	1%	309-021

† R145 concentric with R26 and R230. Furnished as a unit.

†† Furnished as a unit with R26, R230 and SW145.

Resistors (continued)

							Tektronix Part Number
R211		1.5 meg	1/2 w	Fixed	Prec.	1%	309-017
R214A,B		2 x 20 k	2 w	Var.	Comp.	HORIZ. POS.	311-090
R215		560 Ω	1/2 w				302-561
R216		47 Ω	1/2 w				302-470
R218		47 k	2 w				306-473
R222	X1001-up	100 k	1/2 w				302-104
R224		120 k	1/2 w	Fixed	Prec.	1%	309-091
R225		50 k	.1 w	Var.	Comp.	SW. GAIN ADJ.	311-078
R230	101-870†	100 k	1/2 w	Var.	Comp.	EXT. SW. ATTEN.	311-087
	871-up††	100 k	1/2 w	Var.	Comp.	EXT. SW. ATTEN.	311-099
R233		400 k	1/2 w	Fixed	Prec.	1%	309-126
R234		250 k	1/2 w	Fixed	Prec.	1%	309-109
R235		50 k	2 w	Var.	Comp.	Norm. Mag. Regis.	311-023
R237	101-2125	47 Ω	1/2 w				Use 302-101
	2126-up	100 Ω	1/2 w				302-101
R240		68 k	2 w				306-683
R244		47 Ω	1/2 w				302-470
R246		30 k	5 w	Fixed	Mica Plate		*310-507
R250		47 Ω	1/2 w				302-470
R253		41.5 k	5 w	Fixed	Mica Plate		*310-512
R256		10 k	5 w	Fixed	WW	5%	308-054
R257		15 k	1 w				304-153
R258		15 k	1 w				304-153
R259		2.5 k	1/2 w	Var.	Comp.	Mag. Gain Adj.	311-086
R265		22 k	1 w				304-223
R266		100 k	1/2 w				302-104
R267		5.6 k	1/2 w				302-562
R270		47 Ω	1/2 w				302-470
R272		7-35 k	5 w	Fixed	Mica Plate		*310-524
R274		47 Ω	1/2 w				302-470
R280		270 k	1 w				304-274
R301		27 Ω	1/2 w				302-270
R302		27 Ω	1/2 w				302-270
R306		500 k	1/2 w	Fixed	Prec.	1%	309-003
R307		1 meg	1/2 w	Fixed	Prec.	1%	309-014
R312	101-1000	800 k	1/2 w	Fixed	Prec.	1%	309-110
	1001-up	750 k	1/2 w	Fixed	Prec.	1%	309-010
R313	101-1000	250 k	1/2 w	Fixed	Prec.	1%	309-109
	1001-up	333 k	1/2 w	Fixed	Prec.	1%	309-053
R316		900 k	1/2 w	Fixed	Prec.	1%	309-111
R317		111 k	1/2 w	Fixed	Prec.	1%	309-046
R320		990 k	1/2 w	Fixed	Prec.	1%	309-013
R321		10.1 k	1/2 w	Fixed	Prec.	1%	309-034
R325		47 Ω	1/2 w				302-470
R326		100 Ω	1/2 w				302-101
R327		1 meg	1/2 w	Fixed	Prec.	1%	309-014
R330		100 k	1/2 w				302-104
R331		100 Ω	1/2 w				302-101
R332	101-4803	47 Ω	1/2 w				302-470
	4804-up	120 Ω	1/2 w				302-121

† R230 concentric with R26 and R145. Furnished as a unit.

†† Furnished as a unit with R26, R145 and SW145.

Resistors (continued)

							Tektronix Part Number
R334		39 k	2 w				306-393
R335		39 k	2 w				306-393
R338		100 k	2 w	Var.	Comp.	DC Bal.	311-026
R339		390 k	1/2 w				302-394
R341		1.5 meg	1/2 w				302-155
R342		3.9 k	1/2 w				302-392
R344		100 Ω	1/2 w				302-101
R350		10 Ω	1/2 w				302-100
R351	101-1000	1 k	1/2 w	Fixed	Mica Plate	1%	*310-519
	1001-up	1.6 k	1/2 w	Fixed	Mica Plate	1%	*310-531
R352	101-1162	33 k	1/2 w				302-333
	1163-up	68 k	1/2 w				302-683
R353	101-1000	4.7 k	1 w				304-472
	1001-1613	2.7 k	2 w				306-272
	1614-up	8 k	5 w	Fixed	WW	5%	308-053
R354	101-1000	4.7 k	1 w				304-472
	1001-1613	2.7 k	2 w				306-272
	1614-up	8 k	5 w	Fixed	WW	5%	308-053
R355	101-1000	4.5 k	5 w	Fixed	WW	5%	308-066
	1001-1613	2 k	5 w	Fixed	WW	5%	308-003
	1614-up	1 k	1/2 w				302-102
R356	101-1821	375 Ω		Var.	WW	VARIABLE	Use 050-044
R356	1872-up	375 Ω		Var.	WW	VARIABLE	Use *311-284
R357		100 k	1/2 w				302-104
R358	101-1000	3.9 k	1/2 w				302-392
	1001-1613X	100 Ω	1/2 w				302-101
R359	X1001-1613X	3 k	5 w	Fixed	WW	5%	308-082
R360		10 Ω	1/2 w				302-100
R361	101-1000	1 k	1/2 w	Fixed	Mica Plate	1%	*310-519
	1001-up	1.6 k	1/2 w	Fixed	Mica Plate	1%	*310-531
R362	101-1162	33 k	1/2 w				302-333
	1163-up	68 k	1/2 w				302-683
R364	101-1000	68 k	1/2 w				302-683
	1001-up	100 k	1/2 w				302-104
R365	101-1000	68 k	1/2 w				302-683
	1001-up	100 k	1/2 w				302-104
R368		2 x 100 k	2 w	Var.	Comp.	VERT. POS.	311-028
R373		47 Ω	1/2 w				302-470
R376	101-1000	4 k	5 w	Fixed	WW	5%	308-051
	1001-1613	1.2 k	5 w	Fixed	WW	5%	308-063
	1614-up	6 k	5 w	Fixed	WW	5%	308-052
R377	101-1613X	47 Ω	1/2 w				302-470
R378	101-1613	10 k	2 w				306-103
	1614-2439	6.8 k	2 w				306-682
	2440-up	8.2 k	2 w				306-822
R379	101-1613	10 k	2 w				306-103
	1614-2439	6.8 k	2 w				306-682
	2440-up	8.2 k	2 w				306-822

Resistors (continued)

Tektronix
Part Number

R383		47 Ω	$\frac{1}{2}$ w					302-470
R390		47 Ω	$\frac{1}{2}$ w					302-470
R393	101-1613	470 k	$\frac{1}{2}$ w					302-474
	1614-up	100 k	$\frac{1}{2}$ w					302-104
R396		100 Ω	2 w	Var.	Comp.	Gain Adj.		311-003
R398	101-1613	3.5 k	5 w	Fixed	WW	5%		308-080
	1614-2216	2.3 k	5 w	Fixed	WW	5%		308-115
	2217-up	2.5 k	5 w	Fixed	WW	5%		308-120
R399	101-1613	3.5 k	5 w	Fixed	WW	5%		308-080
	1614-2216	2.3 k	5 w	Fixed	WW	5%		308-115
	2217-up	2.5 k	5 w	Fixed	WW	5%		308-120
R400		47 Ω	$\frac{1}{2}$ w					302-470
R401	X5850-up	680 Ω	$\frac{1}{2}$ w	Fixed	Comp.			302-681
R403	101-1613	470 k	$\frac{1}{2}$ w					302-474
	1614-up	100 k	$\frac{1}{2}$ w					302-104
R405	101-1000	3.6 k	1 w	Fixed	Comp.	5%		303-362
	1001-1162	8 k	5 w	Fixed	WW	5%		308-053
	1163-1613	5.6 k	2 w					306-562
	1614-2216	3.9 k	2 w					306-392
	2217-up	2.7 k	2 w					306-272
R410		680 Ω	$\frac{1}{2}$ w					302-681
R412		100 Ω	$\frac{1}{2}$ w					302-101
R413		39 k	2 w					306-393
R415		100 Ω	$\frac{1}{2}$ w					302-101
R416		1 k	$\frac{1}{2}$ w					302-102
R419		39 k	2 w					306-393
R485		1 k	5 w	Fixed	Mica Plate	1%		*310-523
R486		1 k	5 w	Fixed	Mica Plate	1%		*310-523
R487	X1614-up	470 Ω	$\frac{1}{2}$ w					302-471
R490	101-1000	1.2 k	10 w	Fixed	WW	5%		308-086
	1001-1613	1.2 k	5 w	Fixed	WW	5%		308-063
	1614-up	1 k	5 w	Fixed	WW	5%		308-106
R550		150 k	$\frac{1}{2}$ w					302-154
R551		1 k	$\frac{1}{2}$ w					302-102
R552	101-4803	3.3 meg	$\frac{1}{2}$ w					302-335
	4804-up	3.9 meg	$\frac{1}{2}$ w					302-395
R554	101-4803	2.7 meg	$\frac{1}{2}$ w					302-275
	4804-up	2.4 meg	$\frac{1}{2}$ w	Fixed	Comp.	5%		301-245
R555		1 k	$\frac{1}{2}$ w					302-102
R557		68 k	$\frac{1}{2}$ w					302-683
R558		33 k	$\frac{1}{2}$ w					302-333
R560		10 k	2 w	Var.	Comp.	Cal. Adj.		311-016
R561	101-4803	100 k	$\frac{1}{2}$ w					302-104
	4804-up	68 k	$\frac{1}{2}$ w					302-683
R563		100 Ω	$\frac{1}{2}$ w					302-101
R570		10 k	$\frac{1}{2}$ w	Fixed	Prec.	1%		309-100
R571		6 k	$\frac{1}{2}$ w	Fixed	Prec.	1%		309-099
R572		2 k	$\frac{1}{2}$ w	Fixed	Prec.	1%		309-098
R573		1 k	$\frac{1}{2}$ w	Fixed	Prec.	1%		309-115

Resistors (continued)

							Tektronix Part Number
R574		600 Ω	$\frac{1}{2}$ w	Fixed	Prec.	1%	309-097
R575		200 Ω	$\frac{1}{2}$ w	Fixed	Prec.	1%	309-073
R576		100 Ω	$\frac{1}{2}$ w	Fixed	Prec.	1%	309-112
R577		60 Ω	$\frac{1}{2}$ w	Fixed	Prec.	1%	309-067
R578		20 Ω	$\frac{1}{2}$ w	Fixed	Prec.	1%	309-064
R579		10 Ω	$\frac{1}{2}$ w	Fixed	Prec.	1%	309-096
R580		10 Ω	$\frac{1}{2}$ w	Fixed	Prec.	1%	309-096
R600		50 Ω	2 w	Var.	WW	SCALE Illum.	311-055
R601		10 Ω	2 w				306-100
R602		33 k	$\frac{1}{2}$ w				302-333
R607		470 k	$\frac{1}{2}$ w				302-474
R608		1 k	$\frac{1}{2}$ w				302-102
R609	X4804-up	5.6 k	$\frac{1}{2}$ w				302-562
R610	X4804-up	82 k	$\frac{1}{2}$ w				302-823
R611		18 k	$\frac{1}{2}$ w				302-183
R613		1 meg	$\frac{1}{2}$ w				302-105
R616		68 k	$\frac{1}{2}$ w	Fixed	Prec.	1%	309-042
R617		10 k	2 w	Var.	WW	-150 V Adj.	311-015
R618		50 k	$\frac{1}{2}$ w	Fixed	Prec.	1%	309-090
R620		1 k	10 w	Fixed	WW	5%	308-089
R630		10 Ω	1 w				304-100
R631	101-1326	33 k	$\frac{1}{2}$ w				302-333
	1327-up	47 k	$\frac{1}{2}$ w				302-473
R632	101-1326	150 k	$\frac{1}{2}$ w				302-154
	1327-up	33 k	$\frac{1}{2}$ w				302-333
R633	101-1326	680 k	$\frac{1}{2}$ w				302-684
	1327-up	330 k	$\frac{1}{2}$ w				302-334
R635		1 meg	$\frac{1}{2}$ w				302-105
R636		1 k	$\frac{1}{2}$ w				302-102
R639		333 k	$\frac{1}{2}$ w	Fixed	Prec.	1%	309-053
R640		490 k	$\frac{1}{2}$ w	Fixed	Prec.	1%	309-002
R645		180 k	$\frac{1}{2}$ w				302-184
R646		47 k	$\frac{1}{2}$ w				302-473
R650		100 k	$\frac{1}{2}$ w				302-104
R660	101-4803	10 Ω	2 w				306-100
	4804-up	15 Ω	2 w				306-150
R661	101-1326	680 k	$\frac{1}{2}$ w				302-684
	1327-up	270 k	$\frac{1}{2}$ w				302-274
R662	101-1326	180 k	$\frac{1}{2}$ w				302-184
	1327-4803	47 k	$\frac{1}{2}$ w				302-473
	4804-up	33 k	$\frac{1}{2}$ w				302-333
R663	101-1326X	330 k	$\frac{1}{2}$ w				302-334
R665	101-1326	470 k	$\frac{1}{2}$ w				302-474
	1327-up	1 meg	$\frac{1}{2}$ w				302-105
R666		1 k	$\frac{1}{2}$ w				302-102
R667	101-799	1 k	20 w	Fixed	WW	5%	Use 308-037
	800-1613	1 k	25 w	Fixed	WW	5%	308-037
	1614-up	1.25 k	25 w	Fixed	WW	5%	308-102
R668	X1001-1227X	4 k	5 w	Fixed	WW	5%	308-051
R669		610 k	$\frac{1}{2}$ w	Fixed	Prec.	1%	309-006

Resistors (continued)

							Tektronix Part Number
R671		300 k	1/2 w	Fixed	Prec.	1%	309-125
R700		1 k	1/2 w				302-102
R703		47 k	2 w				306-473
R704		47 k	1/2 w				302-473
R706		1.5 k	1/2 w				302-152
R708		390 Ω	1 w				304-391
R710		470 k	1/2 w				302-474
R712		47 Ω	1/2 w				302-470
R722		10 k	1/2 w				302-103
R731		1 meg	2 w	Var.	Comp.	INTENSITY	311-041
R732		6.8 meg	2 w				306-685
R733		6.8 meg	2 w				306-685
R734	101-5189	100 k	1/2 w				302-104
	5190-up	33 k	1/2 w				302-333
R735		1 meg	1/2 w				302-105
R740		2.2 meg	1/2 w				302-225
R741		2 meg	2 w	Var.	Comp.	—1675 Adj.	311-042
R742		3.3 meg	2 w				306-335
R743		2 meg	2 w	Var.	Comp.	FOCUS	311-043
R744		1 meg	1/2 w				302-105
R747		27 k	1/2 w				302-273
R748		1 meg	1/2 w				302-105
R750		100 k	1/2 w				302-104
R751		120 k	1/2 w				302-124
R753		100 k	2 w	Var.	Comp.	Geom. Adj.	311-026
R754		100 k	2 w	Var.	Comp.	ASTIGMATISM	311-026

Rectifiers

SR601	101-4029X	6-250 ma plates/leg					*106-030
SR610	101-4029X	1-500 ma plate/leg					*106-006
SR630	101-4029X	5-250 ma plates/leg					*106-031
SR660	101-4029X	6-250 ma plates/leg					*106-030

Note: A kit is available to convert from Selenium Rectifiers to Silicon Diodes, Order Mod Kit #040-205.

Switches

				Wired	Unwired
SW5 & SW20		Rotary	TRIGGER SELECTOR	*262-123	*260-151
SW145	X871-up	Rotary	With potentiometer		311-099
SW160	101-2427	Rotary	TIME/CM	*262-122	*260-174
	2428-up	Rotary	TIME/CM	*262-182	*260-226
SW200	101-1000	Rotary	HORIZONTAL DISPLAY	050-027	*260-153
	1001-6549	Rotary	HORIZONTAL DISPLAY	050-027	*260-186
	6550-up	Rotary	HORIZONTAL DISPLAY	*262-430	*260-186
SW301		Rotary	INPUT SELECTOR	*262-124	*260-152
SW321	101-1000	Rotary	VOLTS/CM	*262-110	*260-149
SW321	1001-up	Rotary	VOLTS/CM	*262-478	*260-478
SW550		Rotary	SQ. WAVE CAL.	*262-120	*260-098
SW600		Toggle	POWER ON		260-134

Transformers

				Tektronix Part Number
T600	101-4423	Plate & Heater Supply	117 V operation	*120-080
		Plate & Heater Supply	234 V operation	*120-087
T701	4424-up	Plate & Heater Supply		*120-142
		CRT Supply		*120-079

Thermal Cutout

TK601		137° F		260-120
-------	--	--------	--	---------

Electron Tubes and Semiconductors

V10	101-4803	6U8		154-033
	4804-up	6DJ8		154-187
V30	101-4803	6U8		154-033
	4804-up	6DJ8		154-187
V110	101-4803	6BQ7A		154-028
	4804-up	6DJ8		154-187
V120		6AN8		154-078
V140		12AT7		154-039
V150		6AL5		154-016
V160		6AN8		154-078
V180	101-4803	6BQ7A		154-028
	4804-up	6DJ8		154-187
V210	101-4803	6BQ7A		154-028
	4804-up	6DJ8		154-187
V250	101-4803	6BQ7A		154-028
	4804-up	6DJ8		154-187
V270	101-4803	6BQ7A		154-028
	4804-up	6DJ8		154-187
V330		6AU6		154-022
V340		6AU6		154-022
V350		12BY7		154-047
V360		12BY7		154-047
V370	101-4803	6BQ7A		154-028
	4804-up	6DJ8		154-187
V390		6CL6		154-031
V400		6CL6		154-031
V410	101-4803	6BQ7A		154-028
	4804-up	6DJ8		154-187
V550	101-4803	6U8		154-033
	4804-up	6AU6		154-022
V570	101-4803	6BQ7A		154-028
	4804-up	12AU7		154-041
V602		5651		154-052
V607		6AN8		154-078
V610		6AU5		154-021

Electron Tubes and Semiconductors (continued)

		Tektronix Part Number
V631	6AU6	154-022
V635	6080/6AS7GA	154-056
V661	6AU6	154-022
V705	6AQ5	154-017
V710	12AU7	154-041
V720	5642	154-051
V721	5642	154-051
V724	5642	154-051
V859	T55 CRT, P31 Standard Phosphor	*154-344

Type 515A Mechanical Parts List

	Tektronix Part Number
ADAPTOR, BINDING POST	013-004
ADAPTOR, POWER CORD, 3 WIRE TO 2 WIRE SN 2398-up	103-013
ANGLE, FRAME, BOTTOM, BLUE WRINKLE SN 101-5153	122-022
ANGLE, FRAME, BOTTOM, BLUE VINYL SN 5154-up	122-068
ANGLE, FRAME, TOP LEFT SN 4804-up	122-060
BAR, $\frac{3}{16} \times \frac{1}{2} \times 1\frac{3}{4}$ W/2 8-32 TAPPED HOLES	381-073
BAR, TOP SUPPORT, (W/HANDLES 367-011) BLUE WRINKLE SN 101-5153	381-120
BAR, TOP SUPPORT, (W/HANDLES 367-011), BLUE VINYL SN 5154-up	381-148
BAR, SUPPORT, $8\frac{3}{4} \times \frac{1}{4} \times \frac{1}{4}$	381-133
BASE, CRT ROTATOR, BLACK SN 4804-up	432-022
BRACKET, POT, $1 \times 2\frac{17}{32} \times \frac{7}{16}$	406-024
BRACKET, $1 \times 1\frac{1}{16} \times \frac{1}{2}$	406-109
BRACKET, $1 \times 1\frac{3}{16} \times \frac{3}{8}$	406-148
BRACKET, HORIZ. DISPLAY SWITCH	406-218
BRACKET, DELAY LINE SUPPORT, $\frac{7}{16} \times 2\frac{5}{16} \times 1\frac{5}{16} \times \frac{1}{2}$	406-220
BRACKET, POT (5), $1 \times 2\frac{1}{8} \times 7\frac{3}{8}$	406-221
BRACKET, RECTIFIER, $2\frac{1}{16} \times 7\frac{3}{16}$ SN 101-4029	406-222
BRACKET, MOUNTING CAP, $1\frac{1}{8} \times 4\frac{25}{32} \times 1\frac{3}{8}$	406-224
BRACKET, CRT SPRING	406-239
BRACKET, CRT SUPPORT SN 4804-up	406-368
BRACKET, SWITCH MTG., $\frac{5}{8} \times \frac{1}{2} \times 2\frac{1}{4}$ SN 2199-up	406-482
BRACKET, SILICON DIODE MTG., $7\frac{3}{16} \times 2\frac{11}{16}$ SN 4030-up	406-493
BUSHING, $\frac{3}{8}$ -32 $\times \frac{9}{16} \times .412$	358-010
BUSHING, $\frac{3}{8}$ -32 $\times 1\frac{3}{16} \times .252$	358-029
BUSHING, FOR 5-WAY BINDING POSTS	358-036
CABLE HARNESS, SWEEP SN 101-4803	179-130
CABLE HARNESS, SWEEP SN 4804-up	179-386
CABLE HARNESS, F & I SN 101-4803	179-131
CABLE HARNESS, HV CONNECTOR CABLE	179-132
CABLE HARNESS, POWER SN 101-4029	179-133
CABLE HARNESS, POWER SN 4030-up	179-352
CABLE HARNESS, 110 V	179-134
CAM, GRATICULE, NYLON	401-004
CAP, FUSE	200-015

Mechanical Parts List (continued)

	Part Number Tektronix
CHASSIS, SWEEP SN 101-4803	441-127
CHASSIS, SWEEP SN 4804-up	441-286
CHASSIS, VA & POWER SN 101-4803	441-128
CHASSIS, VA & POWER SN 4804-up	441-301
CHASSIS, DELAY LINE 9 ³ / ₄ "	441-129
CHASSIS, DELAY LINE 7 ³ / ₄ "	441-131
CHASSIS, F & I SN 101-4803	441-138
CHASSIS, F & I SN 4804-up	441-272
CLAMP, CABLE, 5/8" PLASTIC	343-007
CLAMP, 1/2 ID STEEL	343-015
CONNECTOR, MOTOR BASE RECESSED, 2 WIRE	131-010
CONNECTOR, 83-1 RTY, 1 CONDUCTOR	131-038
CONNECTOR, MOTOR BASE, 3 WIRE	131-102
CORD, POWER, 16 GAUGE, 8 FT., 3 WIRE	161-010
COUPLING,INSULATING NYLON	376-011
COUPLING,POT, WIRE STEEL	376-014
COVER, GRATICULE	200-382
COVER, CRT ANODE & PLATE ASS'Y	200-112
EYELET, 5 & 10 w RESISTOR	210-601
FAN BLADE SN 101-6979	369-001
FAN BLADE SN 6980-up	369-015
FAN MOTOR SN 101-6979	147-001
FAN MOTOR SN 6980-up	147-022
FASTENER, SNAP	214-153
FILTER, AIR	378-010
FILTER, LIGHT, 5" GREEN W/CAM HOLE	378-514
GRATICULE, 5"	331-037
GROMMET, RUBBER, 1/4	348-002
GROMMET, RUBBER, 5/16	348-003
GROMMET, RUBBER, 3/8	348-004
GROMMET, RUBBER, 1/2	348-005
GROMMET, RUBBER, 5/8	348-012
GROMMET, RUBBER, 1 OD x 1/2 ID	348-019
HOLDER, SINGLE NEON BULB	352-008
HOLDER, FUSE	352-010
HOLDER, COIL FORM, W/O PIN	352-016
HOLDER, COIL FORM, W/PIN	352-017
HOUSING, AIR FILTER, BLUE WRINKLE SN 101-5153	380-007
HOUSING, AIR FILTER, BLUE VINYL SN 5154-up	380-017

Mechanical Parts List (continued)

	Tektronix Part Number
JEWEL, PILOT LIGHT	378-518
KNOB, LARGE BLACK 1.225 FLANGE 1/4 INSERT HOLE	366-028
KNOB, LARGE BLACK 1.225 FLANGE 1/4 INSERT HOLE, 1/4 CONC. HOLE	366-029
KNOB, LARGE BLACK 1.225 FLANGE 17/64 INSERT HOLE	366-030
KNOB, SMALL RED .694 DIA. 1/8 INSERT HOLE	366-031
KNOB, SMALL RED .694 DIA. 3/16 INSERT HOLE SN 4804-up	366-032
KNOB, SMALL BLACK	366-033
KNOB, SMALL RED .780 OD 1/8 HOLE PART WAY	366-038
KNOB, LARGE BLACK 1.375 OD 1/4 HOLE THRU	366-040
LOCKWASHER, #4 INT.	210-004
LOCKWASHER, #6 INT.	210-006
LOCKWASHER, #8 EXT.	210-007
LOCKWASHER, #8 INT.	210-008
LOCKWASHER, #10 INT.	210-010
LOCKWASHER, POT, 3/8 x 1/2 INT.	210-012
LOCKWASHER, 3/8 x 11/16 INT.	210-013
LOCKWASHER, #5 SPRING	210-017
LUG, SOLDER, SE 4	210-201
LUG, SOLDER, SE 6 W/2 HOLES	210-202
LUG, SOLDER, DE 6	210-204
LUG, SOLDER, SE 8	210-205
LUG, SOLDER, SE 10	210-206
LUG, SOLDER, 3/8 POT	210-207
MOUNT, FAN MOTOR	426-046
NUT, GRATICULE	210-424
NUT, HEX, CAP, 6-32 x 5/16	210-402
NUT, HEX, 4-40 x 3/16	210-406
NUT, HEX, 6-32 x 1/4	210-407
NUT, HEX, 8-32 x 5/16	210-409
NUT, HEX, 10-32 x 5/16	210-410
NUT, HEX, 3/8-32 x 1/2	210-413
NUT, HEX, 15/32-32 x 9/16	210-414
NUT, HEX, 1-72 x 5/32 (POT)	210-438
NUT, HEX, 3/8-32 x 1/2 x 5/8	210-444
NUT, HEX, 10-32 x 3/8 x 1/8	210-445
NUT, HEX, 5-40 x 1/4	210-449
NUT, KEP, 6-32	210-457

Mechanical Parts List (continued)

	Tektronix Part Number
NUT, KEP, 8-32	210-458
NUT, HEX, 8-32 x 1/2 x 23/64	210-462
NUT, 12 SIDED SWITCH	210-473
NUT, HEX, 6-32 x 5/16 5 & 10 w RESISTOR MTG.	210-478
NUT, 10-32 x 3/8 CRT ROTATOR	210-503
PLATE, 9/16 x 1 17/32 x .040	386-374
PLATE, PLEXIGLAS, 1 1/4 x 6 DELAY LINE	386-485
PLATE, PLEXIGLAS, 1 1/2 x 7 1/2 DELAY LINE	386-486
PLATE, PLEXIGLAS, 1 7/16 x 8 DELAY LINE	386-487
PLATE, STYRENE 1 1/2 x 2 1 1/16 DELAY LINE	386-488
PLATE, CABINET BOTTOM, BLUE WRINKLE SN 101-5153	386-491
PLATE, CABINET BOTTOM, BLUE VINYL SN 5154-up	387-067
PLATE, SUBPANEL, FRONT SN 4030-up	386-493
PLATE, OVERLAY, REAR, BLUE WRINKLE SN 101-5153	386-494
PLATE, OVERLAY, REAR, BLUE VINYL SN 5154-up	387-068
PLATE, SUBPANEL, REAR SN 101-4803	386-495
PLATE, SUBPANEL, REAR SN 4804-up	387-011
PLATE, STYRENE, 1 5/16 x 1 5/8	386-533
PLATE, POT MTG., 3/4 x 7/8	386-768
PLATE, CABINET SIDE, LEFT & RIGHT, BLUE WRINKLE SN 101-5153	386-771
PLATE, CABINET SIDE, LEFT, BLUE VINYL SN 5154-up	387-222
PLATE, CABINET SIDE, RIGHT, BLUE VINYL SN 5154-up	387-223
PLATE, CRT SOCKET BACK	387-344
PLUG, CRT ANODE CONTACT	134-031
POST, BINDING, METAL	129-020
POST, BINDING, 5-WAY BLACK	129-036
RING, FAN	354-051
RING, LOCKING SWITCH, 23/32 OD x 15/32 ID	354-055
RING, CRT ROTATOR W/HANDLE SN 101-4803	354-066
RING, NYLON, CRT ROTATOR SECURING SN 4804-up	354-078
RING, CRT ROTATOR CLAMPING SN 4804-up	354-103
ROD, 1/4 x 2 9/32	384-132
ROD, 1/4 x 7 1/2	384-133
ROD, 1/8 x 5 1 3/16	384-147
ROD, 1/4 x 2 1 3/32 NYLON	384-531
ROD, 5/16 x 1 3/4 NYLON	385-060

Mechanical Parts List (continued)

	Tektronix Part Number
ROD, 1/4 x 9/32 SN 4804-up	385-127
ROD, 3/8 x 2 1/2	385-128
ROD, 5/16 x 5/16 DELRIN	385-135
ROD, 5/16 x 1 1/4 DELRIN	385-136
ROD, 5/16 x 2 1/4 DELRIN	385-137
ROD, 5/16 x 1 9/16 DELRIN	385-138
SCREW, 4-40 x 3/16 BHS	211-007
SCREW, 4-40 x 5/16 BHS	211-011
SCREW, 4-40 x 1/4 FHS	211-023
SCREW, 4-40 x 1 FHS	211-031
SCREW, 4-40 x 5/16 PAN W/LOCKWASHER	211-033
SCREW, 4-40 x 5/16 FHS, PHILLIPS	211-038
SCREW, 6-32 x 3/16 BHS	211-503
SCREW, 6-32 x 1/4 BHS	211-504
SCREW, 6-32 x 5/16 BHS	211-507
SCREW, 6-32 x 3/8 BHS	211-510
SCREW, 6-32 x 1/2 BHS	211-511
SCREW, 6-32 x 3/4 BHS	211-514
SCREW, 6-32 x 5/16 PAN W/LOCKWASHER	211-534
SCREW, 6-32 x 3/8 TRUSS, PHILLIPS	211-537
SCREW, 6-32 x 5/16 FHS, 100°, CSK, PHILLIPS	211-538
SCREW, 6-32 x 1/4 FHS, 100°, CSK, PHILLIPS	211-541
SCREW, 6-32 x 5/16 RHS	211-543
SCREW, 6-32 x 3/4 TRUSS, PHILLIPS	211-544
SCREW, 6-32 x 1 1/2 RHS, PHILLIPS	211-553
SCREW, 6-32 x 3/8 FHS, 100°, CSK, PHILLIPS	211-559
SCREW, 6-32 x 1 RHS	211-560
SCREW, 6-32 x 3/8 HEX SOCKET, FH CAP	211-561
SCREW, 8-32 x 5/16 BHS	212-004
SCREW, 8-32 x 1 1/4 RHS	212-031
SCREW, 8-32 x 1 3/4 FHS	212-037
SCREW, 8-32 x 3/8 TRUSS, PHILLIPS	212-039
SCREW, 8-32 x 3/8 FHS, 100°, CSK, PHILLIPS	212-040
SCREW, 8-32 x 1/2 FHS, 100°, CSK, PHILLIPS	212-043
SCREW, THREAD CUTTING, 4-40 x 3/8 FHS	213-012
SCREW, THREAD CUTTING, 6-32 x 3/8 TRUSS, PHILLIPS	213-041

Mechanical Parts List (continued)

	Tektronix Part Number
SCREW, THREAD CUTTING, 5-32 x 3/16 PAN, PHILLIPS	213-044
SCREW, SELF-TAPPING, 4-40 x 5/16 PAN, PHILLIPS	213-045
SCREW, THREAD CUTTING, NO. 4 x 1/4 PHS, PHILLIPS	213-088
SHIELD, SOCKET, 29/32 ID	337-005
SHIELD, TUBE, 1 1/32 ID W/SPRING, 1 5/16 HI	337-008
SHIELD, CRT	337-088
SHIELD, 1 9/16 x 1 1/8 x .040	337-106
SHIELD, CAL SWITCH	337-134
SHIELD, DELAY LINE	337-135
SHIELD, INPUT SELECTOR	337-136
SHIELD, HV	337-137
SHIELD, F & I POT, REPLACED BY (337-195) SN 101-1613 NP	337-138
SHIELD, VA SN 1614-up	337-195
SHIELD, TIME/CM SWITCH	337-141
SHIELD, VOLT/CM SWITCH	337-145
SHIELD, F & I SN 101-4803	337-147
SHIELD, F & I SN 4804-up	337-318
SHIELD, GRATICULE LIGHT	337-187
SHIELD, SILICON DIODE SN 4030-up	337-319
SHOCKMOUNT, SOLID ROUND RUBBER 1/2' DIA.	348-008
SOCKET, GRATICULE LAMP	136-001
SOCKET, STM7G	136-008
SOCKET, STM8	136-011
SOCKET, STM9G	136-015
SOCKET, JEWEL LIGHT	136-025
SOCKET, TIP JACK, BLACK	136-037
SOCKET, 7-PIN W/1 1/8 DIA. MTG. HOLES	136-044
SOCKET, CRT, 14-PIN	136-046
SPADE BOLT, 6-32 x 3/8	214-012
SPACER, 1/16 (FOR CERAMIC STRIPS)	361-007
SPACER, 5/16 (FOR CERAMIC STRIPS)	361-009
STRAP, HV TRANSFORMER MTG. W/SPADE BOLTS	346-001
STRAP, MTG. 1 x 4 5/16 W/SPADE BOLT	346-002
STRIP, FELT, 1 x 5 3/4	124-068
STRIP, CERAMIC, 3/4 x 4 NOTCHES, CLIP MOUNTED	124-088
STRIP, CERAMIC, 7 NOTCHES, CLIP MOUNTED	124-089

Mechanical Parts List (continued)

	Tektronix Part Number
STRIP, CERAMIC, $\frac{3}{4}$ x 9 NOTCHES, CLIP MOUNTED	124-090
STRIP, CERAMIC, $\frac{3}{4}$ x 11 NOTCHES, CLIP MOUNTED	124-091
STRIP, CERAMIC, $\frac{7}{16}$ x 3 NOTCHES, CLIP MOUNTED	124-092
STRIP, CERAMIC, $\frac{7}{16}$ x 9 NOTCHES, CLIP MOUNTED	124-095
STRIP, CERAMIC, $\frac{3}{4}$ x 1 NOTCHES, CLIP MOUNTED	124-100
STUD, 10-32 x $2\frac{7}{16}$	355-044
STUD, 10-32 x $3\frac{1}{4}$ x $\frac{3}{16}$ CRT ROTATOR SN 4804-up	355-049
TAG, VOLTAGE RATING, 117 v, 105-125 v, 50-60 cycles	334-649
TUBE, $\frac{1}{2}$ OD x 13	166-096
TUBE, $\frac{1}{4}$ OD x $1\frac{23}{32}$ TAPPED 6-32	166-099
WASHER, 6S x $\frac{5}{16}$ x .028	210-802
WASHER, 6L x $\frac{3}{8}$ x .032	210-803
WASHER, 25 w RESISTOR MOUNTING	210-809
WASHER, FIBER #10	210-812
WASHER, RUBBER, 13-20	210-816
WASHER, .390 ID x $\frac{9}{16}$ OD x .020	210-840
WASHER, RUBBER, FUSE HOLDER	210-873
WASHER, .470 ID x $2\frac{1}{32}$ OD x .030	210-902
WASHER, WAVY PHOSPHOR BRONZE	210-914

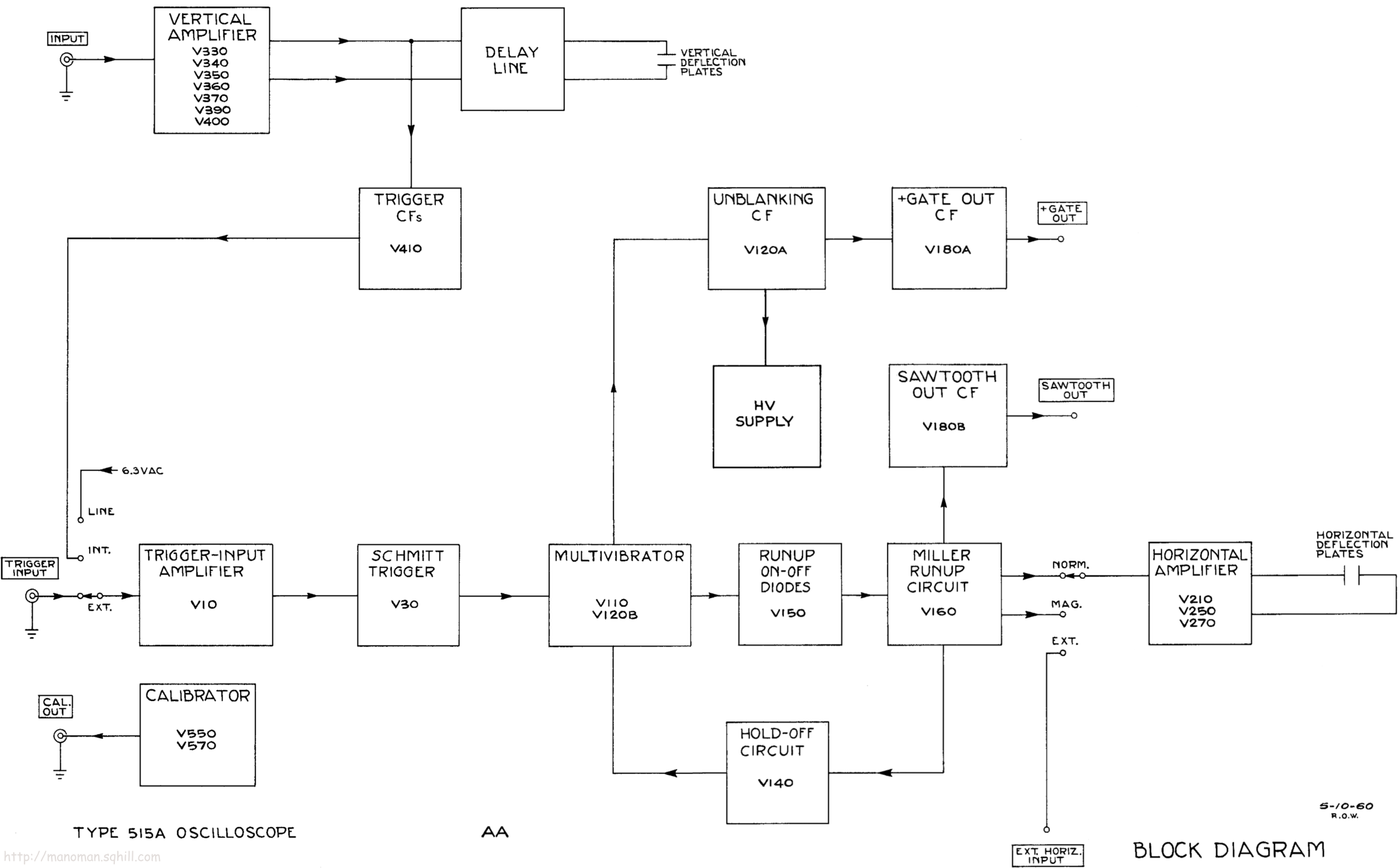

TYPE 515A OSCILLOSCOPE

AA

5-10-60
R.O.W.

BLOCK DIAGRAM

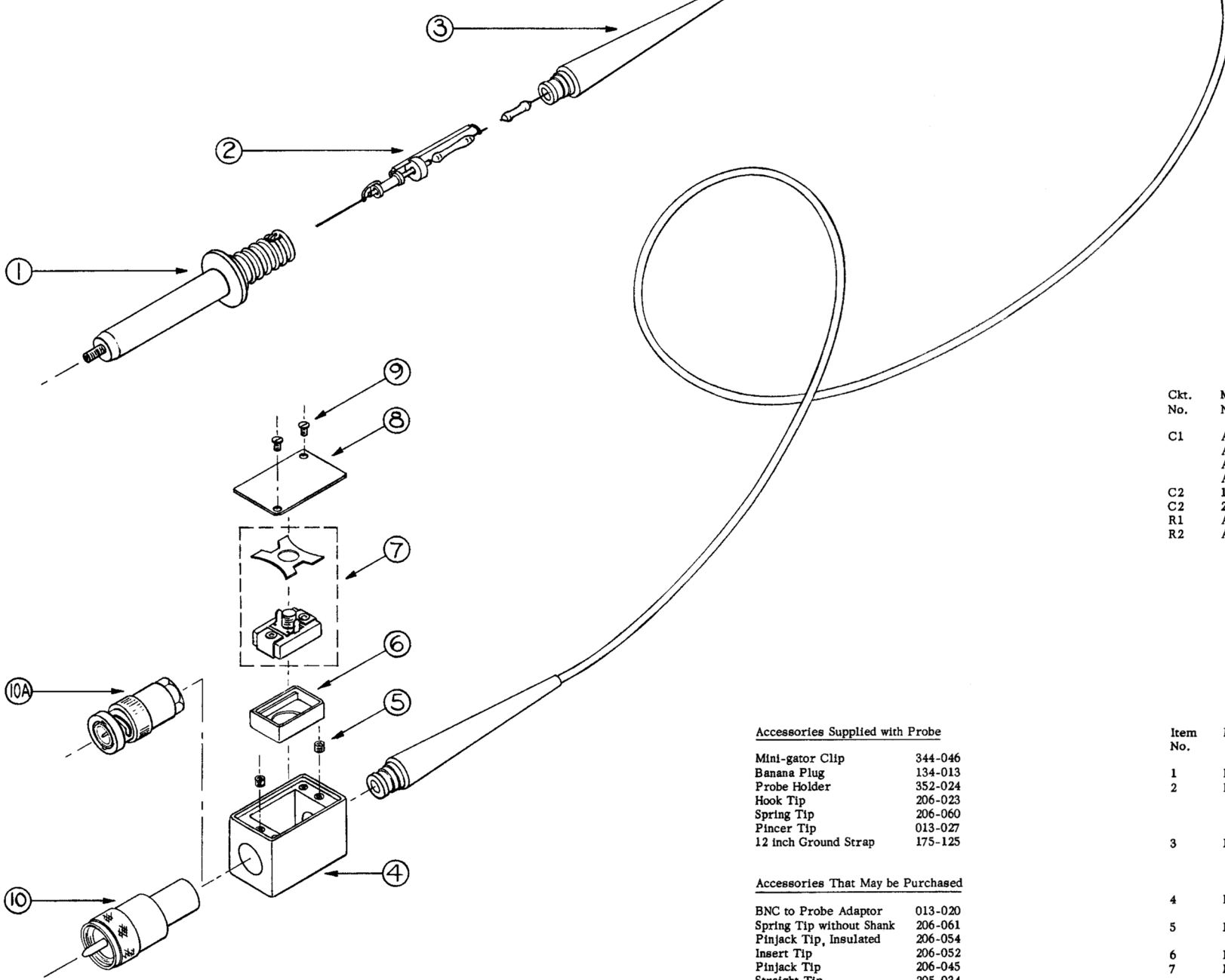
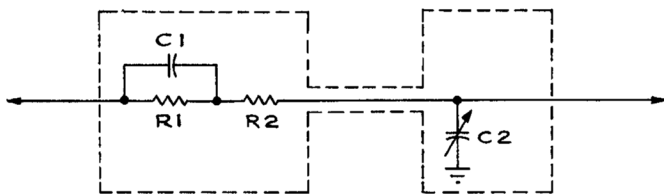

PROBES THIS SHEET COVERS

P6017		
43 inches	Tektronix Part No.	010-038
6 ft.		010-056
9 ft.		010-057
12 ft.		010-058
P6022		
43 inches	Tektronix Part No.	010-064
6 ft.		010-066
9 ft.		010-067
12 ft.		010-068

TABLE I ELECTRICAL PARTS

Ckt. No.	Model No.	Cable Length	Value	Description	Tektronix Part No.
C1	All	43 inches	11 μ f	Cer. Fixed 500v +or- 5%	281-576
	All	6 ft.	14 μ f		281-577
	All	9 ft.	18 μ f		281-578
	All	12 ft.	21 μ f		281-579
C2	1	All Lengths	8-50 μ f	Cer. Var. 500v	281-013
C2	2	All Lengths	5-80 μ f		Mica Var. 500v
R1	All	All Lengths	9 meg	1/2 w Fixed Prec. 2% Selected for proper cable termination. Furnished with cable.	309-232
R2	All	All Lengths			

NOTE

On the underside of the lid for the Compensation Box is the Model Number. If the probe shows no number it will be Model Number One.

TABLE II MECHANICAL PARTS

Item No.	Probe Type	Model No.	Cable Length	Part Title	Tektronix Part No.
1	P6017/P6022	All	All Lengths	Probe Body	204-054
			43 inches		
2	P6017/P6022	All	43 inches	Attenuation Assembly	011-038
			6 ft.		
			9 ft.		
			12 ft.		
3	P6017/P6022	All	43 inches	Cable Assembly	175-143
			6 ft.		
			9 ft.		
			12 ft.		
4	P6017/P6022	1	All Lengths	Compensator Box	202-051
			2		
5	P6017/P6022	All	All Lengths	Allen Set Screws 4-40 x 3/32	213-075
6	P6017/P6022	2 only	All Lengths	Positioning Insulator	200-098
7	P6017/P6022	1	All Lengths	Compensating Capacitor	281-013
			2		
8	P6017/P6022	All	All Lengths	Compensating Capacitor and Spring Clip Assembly	281-059
9	P6017/P6022	All	All Lengths	Plate Cover	200-248
			All Lengths		
10A	P6017	All	All Lengths	Thread Cutting Screw 4-40 x 1/4	213-035
			All Lengths		
10	P6022	All	All Lengths	Connector, UHF	131-058
			All Lengths		
				Connector, BNC	131-186

Accessories Supplied with Probe

Mini-gator Clip	344-046
Banana Plug	134-013
Probe Holder	352-024
Hook Tip	206-023
Spring Tip	206-060
Pincer Tip	013-027
12 inch Ground Strap	175-125

Accessories That May be Purchased

BNC to Probe Adaptor	013-020
Spring Tip without Shank	206-061
Pinjack Tip, insulated	206-054
Insert Tip	206-052
Pinjack Tip	206-045
Straight Tip	205-034
Pinjack Tip, Bent Shank	206-011
BNC Tip	206-015
5 inch Ground Strap	175-124
18 inch Ground Strap	175-184

AA

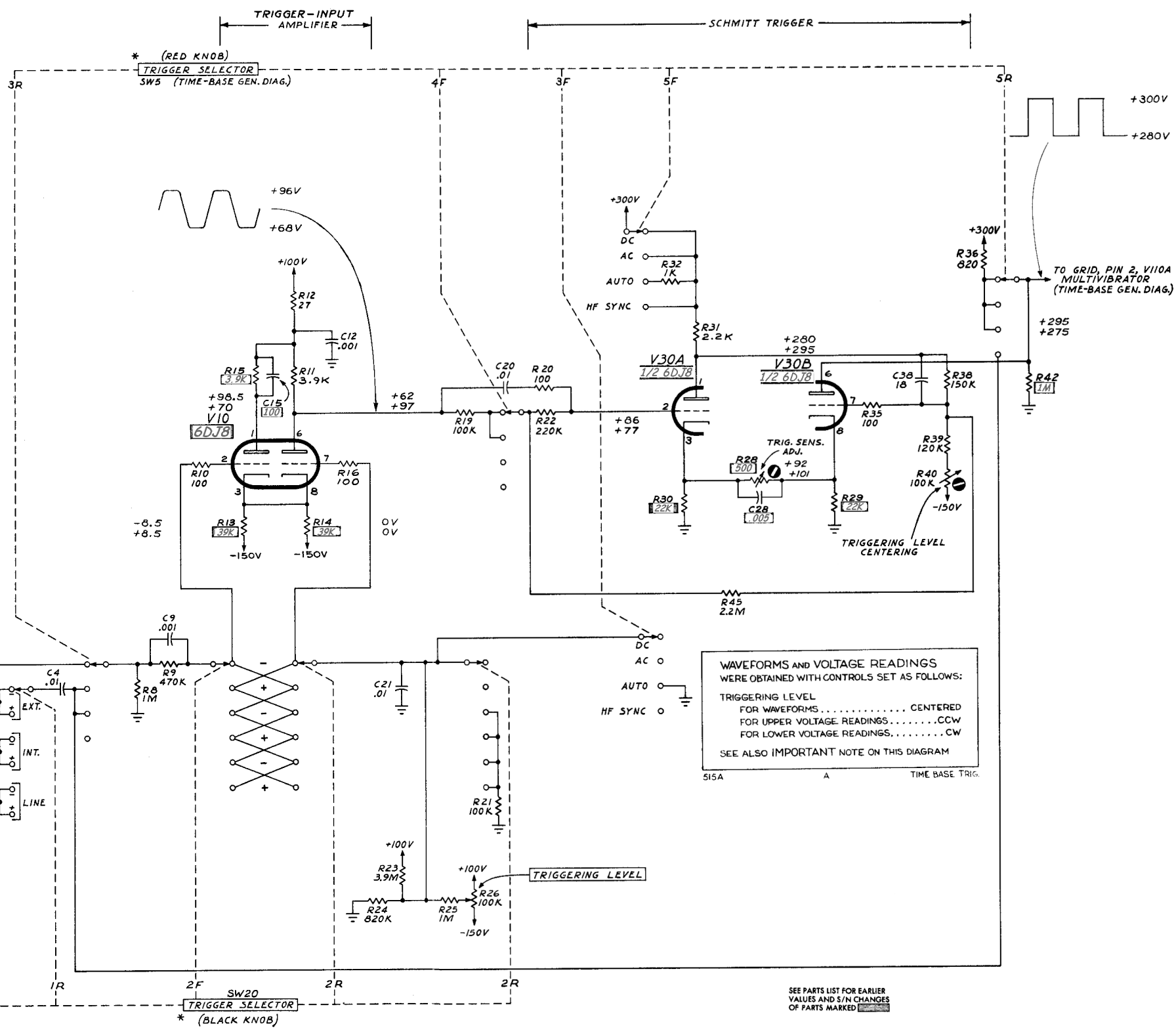

* CONCENTRICALLY MOUNTED

IMPORTANT

WAVEFORMS ARE IDEALIZED BUT CLOSELY APPROXIMATE THOSE TO BE FOUND IN THIS INSTRUMENT PROVIDED CONTROLS ARE SET AS INDICATED BELOW AND ON EACH SCHEMATIC. VOLTAGE READINGS, IF TAKEN WITH A VTVM, WILL BE WITHIN $\pm 10\%$ OF THE INDICATED VALUE. BEFORE STARTING TO CHECK THIS INSTRUMENT THE FOLLOWING CONTROLS SHOULD BE SET AND NOT DISTURBED UNLESS OTHERWISE NOTED ON SCHEMATICS BEING USED. RETURN CONTROLS TO THE POSITIONS LISTED BELOW BEFORE MOVING TO THE NEXT SCHEMATIC.

- SQUARE-WAVE CALIBRATOR OFF
- HORIZONTAL DISPLAY NORM
- VARIABLE (TIME/CH) CW (CALIBRATED)
- TIME/CH 1 mSEC
- TRIGGERING MODE AC
- TRIGGER SLOPE -LINE
- TRIGGERING LEVEL CENTERED
- STABILITY PRESET

WAVEFORMS AND VOLTAGE READINGS WERE OBTAINED WITH CONTROLS SET AS FOLLOWS:

TRIGGERING LEVEL CENTERED
FOR UPPER VOLTAGE READINGS.....	CW
FOR LOWER VOLTAGE READINGS.....	CW

SEE ALSO IMPORTANT NOTE ON THIS DIAGRAM

SEE PARTS LIST FOR EARLIER VALUES AND S/N CHANGES OF PARTS MARKED

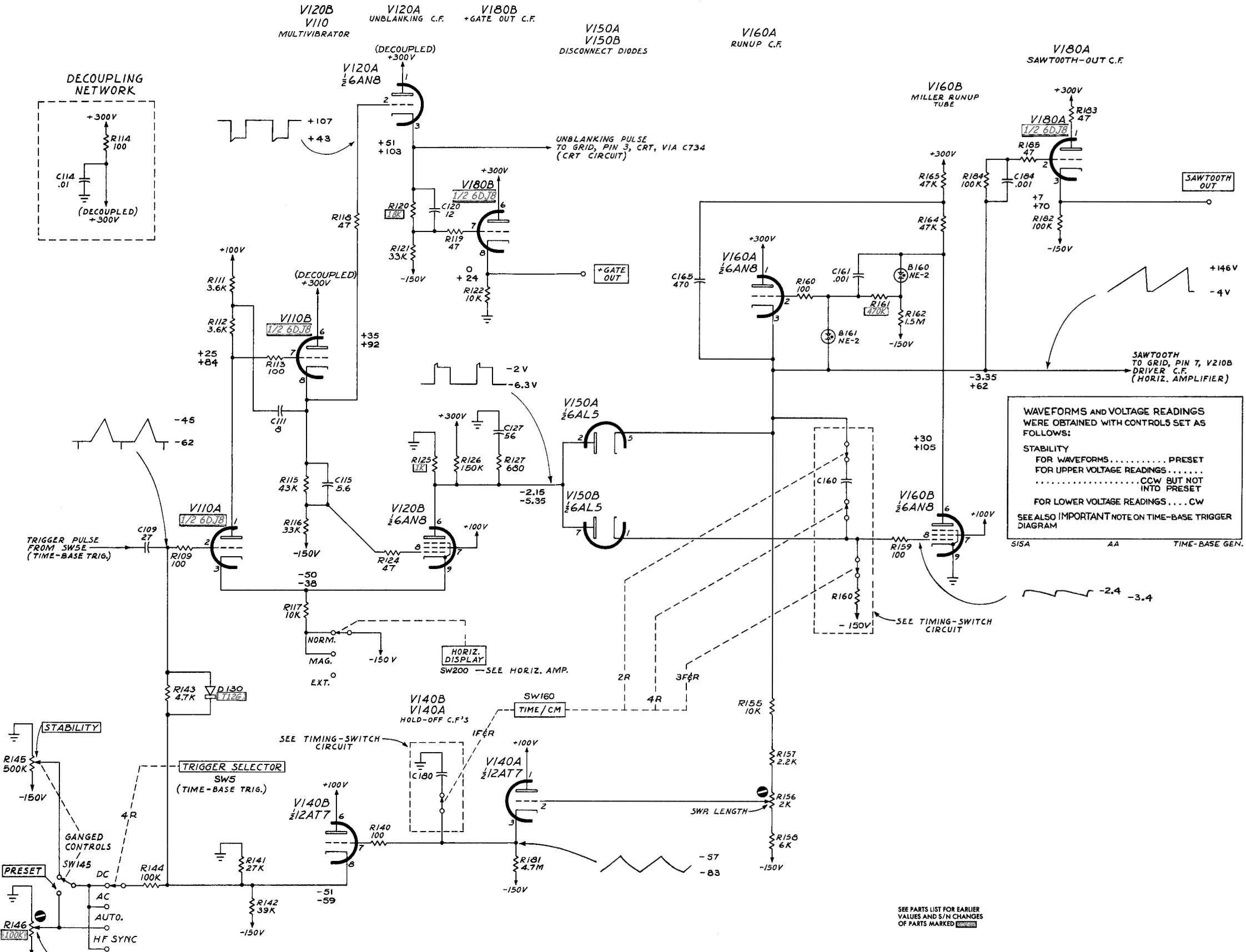
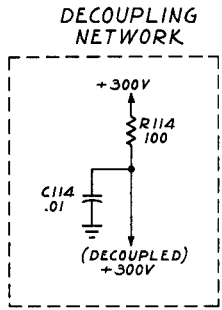

WAVEFORMS AND VOLTAGE READINGS WERE OBTAINED WITH CONTROLS SET AS FOLLOWS:

STABILITY
 FOR WAVEFORMS PRESET
 FOR UPPER VOLTAGE READINGS
 CCW BUT NOT INTO PRESET
 FOR LOWER VOLTAGE READINGS CW

SEE ALSO IMPORTANT NOTE ON TIME-BASE TRIGGER DIAGRAM

SISA AA TIME-BASE GEN.

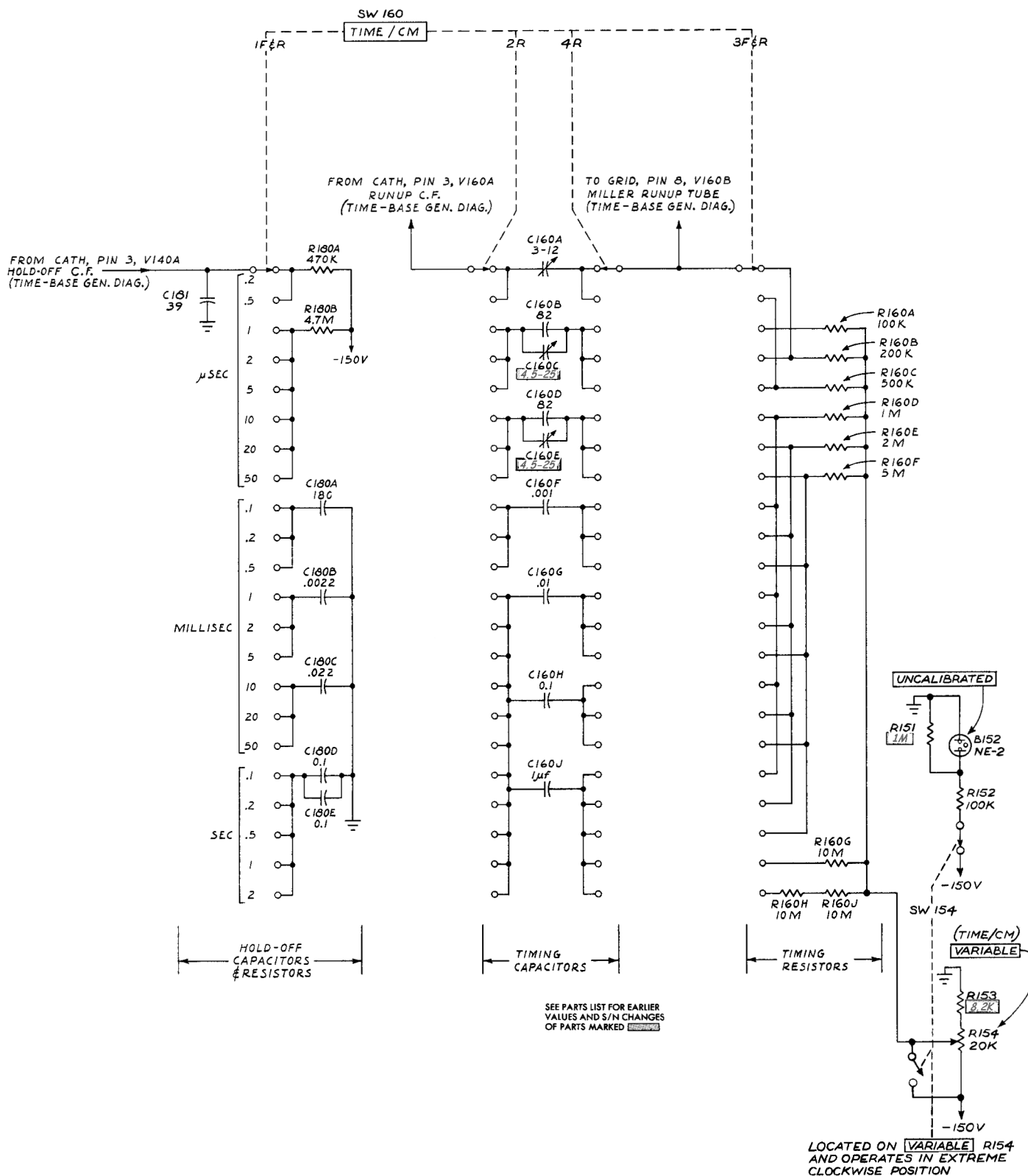

SEE PARTS LIST FOR EARLIER VALUES AND S/N CHANGES OF PARTS MARKED

4-28-61
KF

TIMING SWITCH

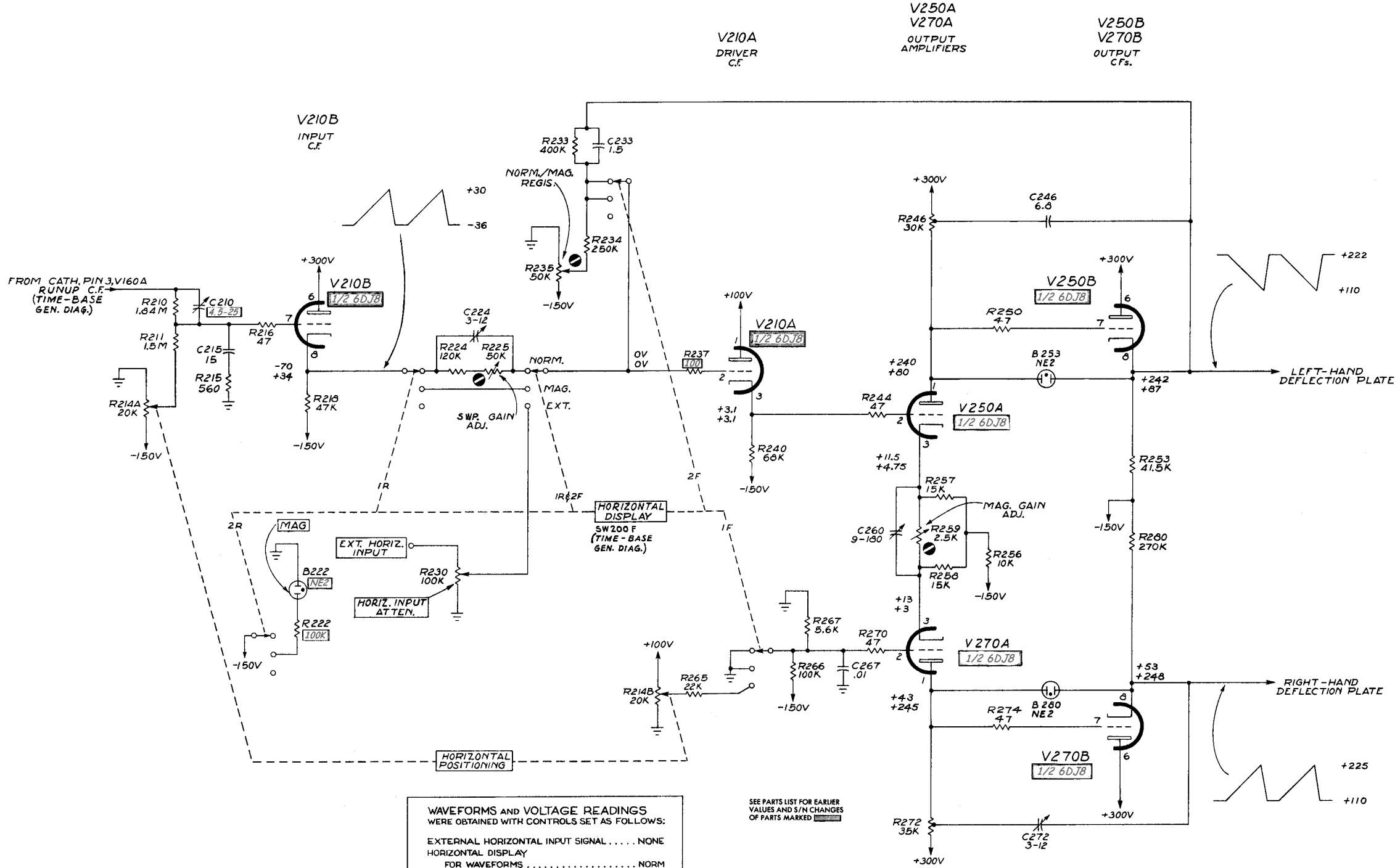

V210A
DRIVER
C.F.

V250A
V270A
OUTPUT
AMPLIFIERS

V250B
V270B
OUTPUT
C.F.s.

V210B
INPUT
C.F.

FROM CATH. PIN 3, V160A
RUNUP C.F.
(TIME-BASE
GEN. DIAG.)

NORM./MAG.
REGIS.

SWP. GAIN
ADJ.

HORIZONTAL
DISPLAY
SW 200 F
(TIME-BASE
GEN. DIAG.)

HORIZONTAL
POSITIONING

EXT. HORIZ.
INPUT

HORIZ. INPUT
ATTEN.

MAG. GAIN
ADJ.

WAVEFORMS AND VOLTAGE READINGS
WERE OBTAINED WITH CONTROLS SET AS FOLLOWS:

EXTERNAL HORIZONTAL INPUT SIGNAL NONE
HORIZONTAL DISPLAY
FOR WAVEFORMS NORM
FOR VOLTAGES. EXT.

HORIZONTAL POSITION
FOR UPPER VOLTAGE READINGS CCW
FOR LOWER VOLTAGE READINGS. CW

SEE ALSO IMPORTANT NOTE ON TIME-BASE TRIGGER DIAGRAM

SEE PARTS LIST FOR EARLIER
VALUES AND S/N CHANGES
OF PARTS MARKED

LEFT-HAND
DEFLECTION PLATE

RIGHT-HAND
DEFLECTION PLATE

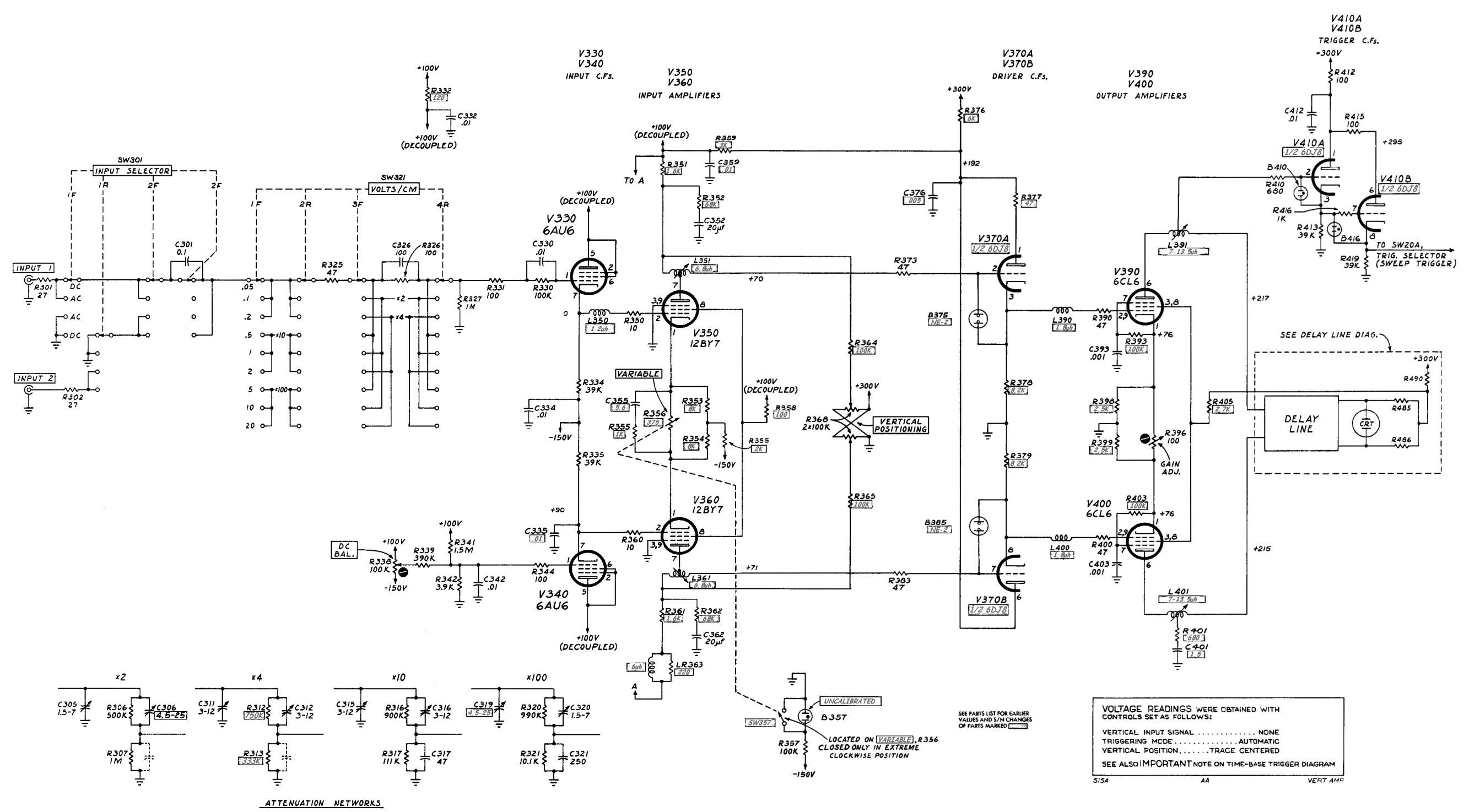

Control	Setting	Voltage Reading
VERTICAL INPUT SIGNAL	NONE	0V
TRIGGERING MODE	AUTOMATIC	0V
VERTICAL POSITION	TRACE CENTERED	0V

SEE ALSO IMPORTANT NOTE ON TIME-BASE TRIGGER DIAGRAM

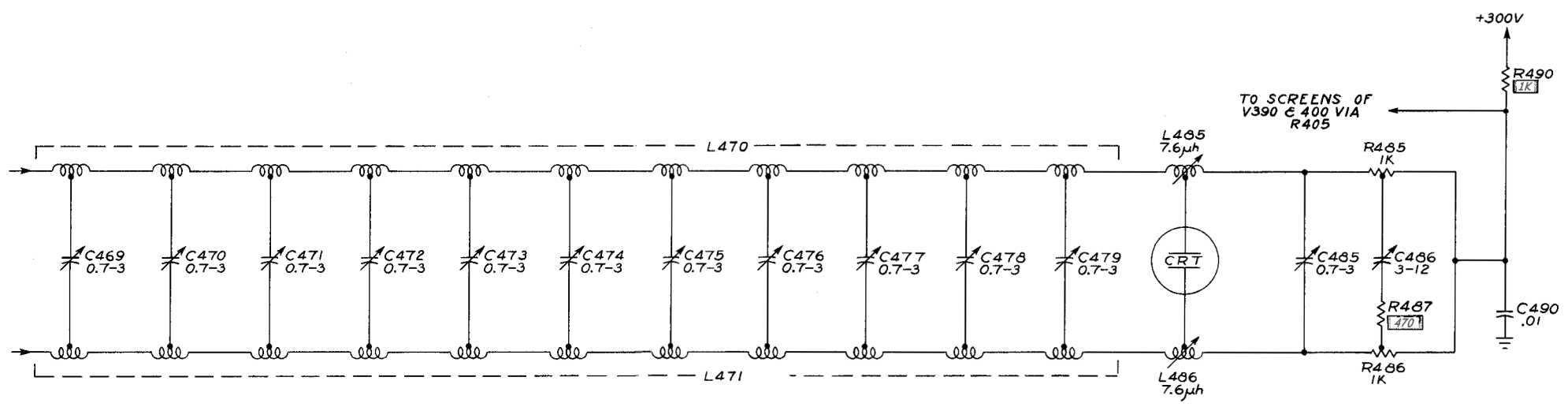
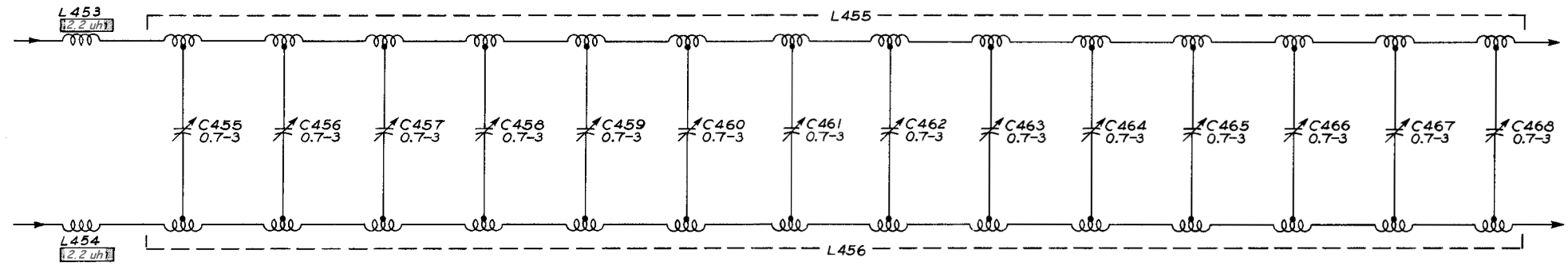
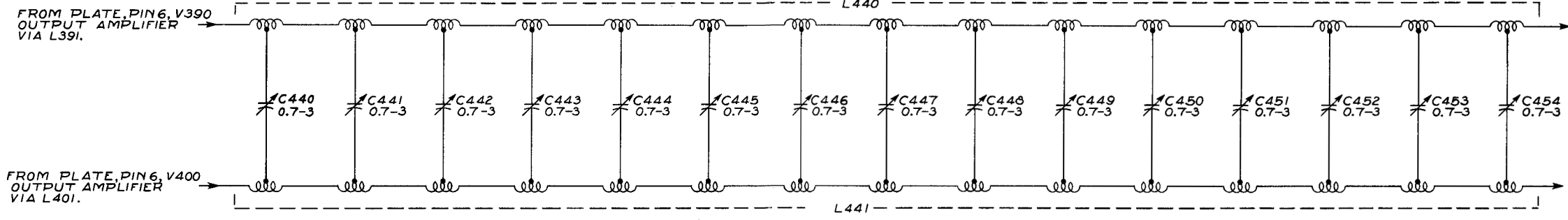

SEE PARTS LIST FOR EARLIER
VALUES AND S/N CHANGES
OF PARTS MARKED

6-16-58
R.O.W.

CALIBRATOR MULTIVIBRATOR

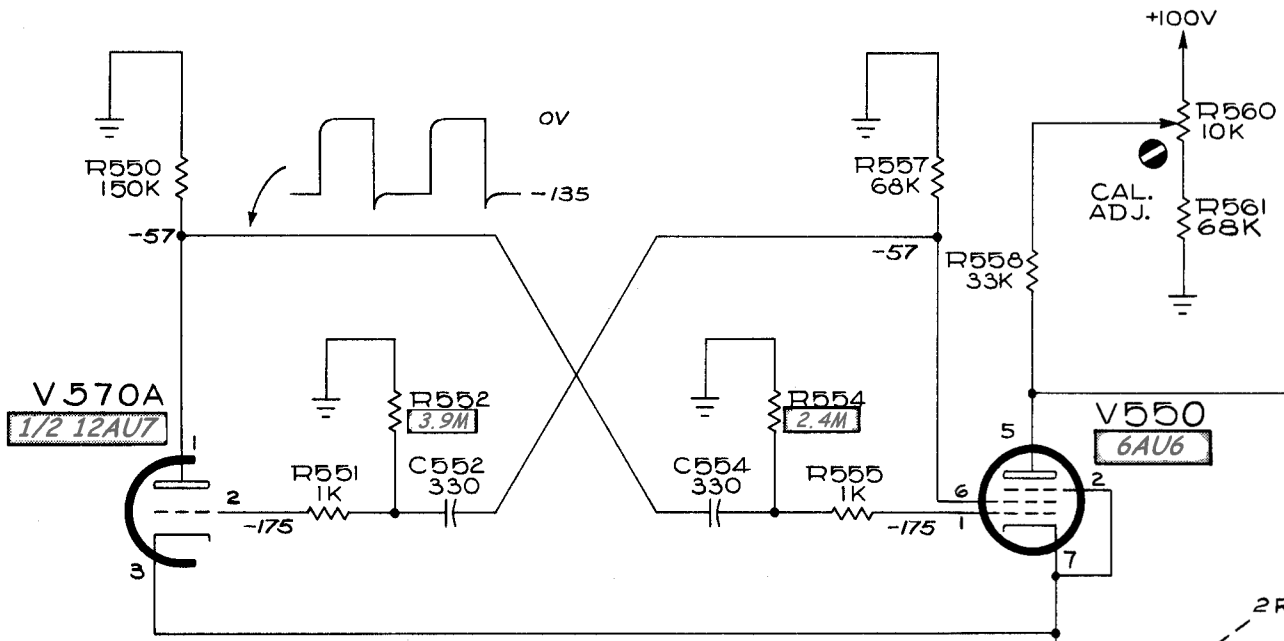

CALIBRATOR C.F.

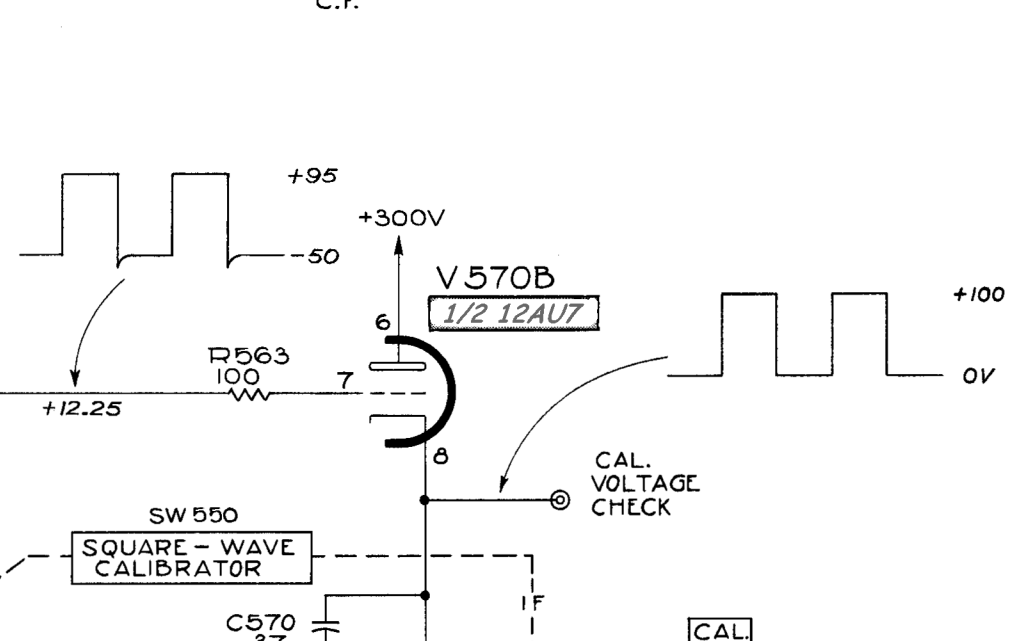

SW 550
SQUARE - WAVE
CALIBRATOR

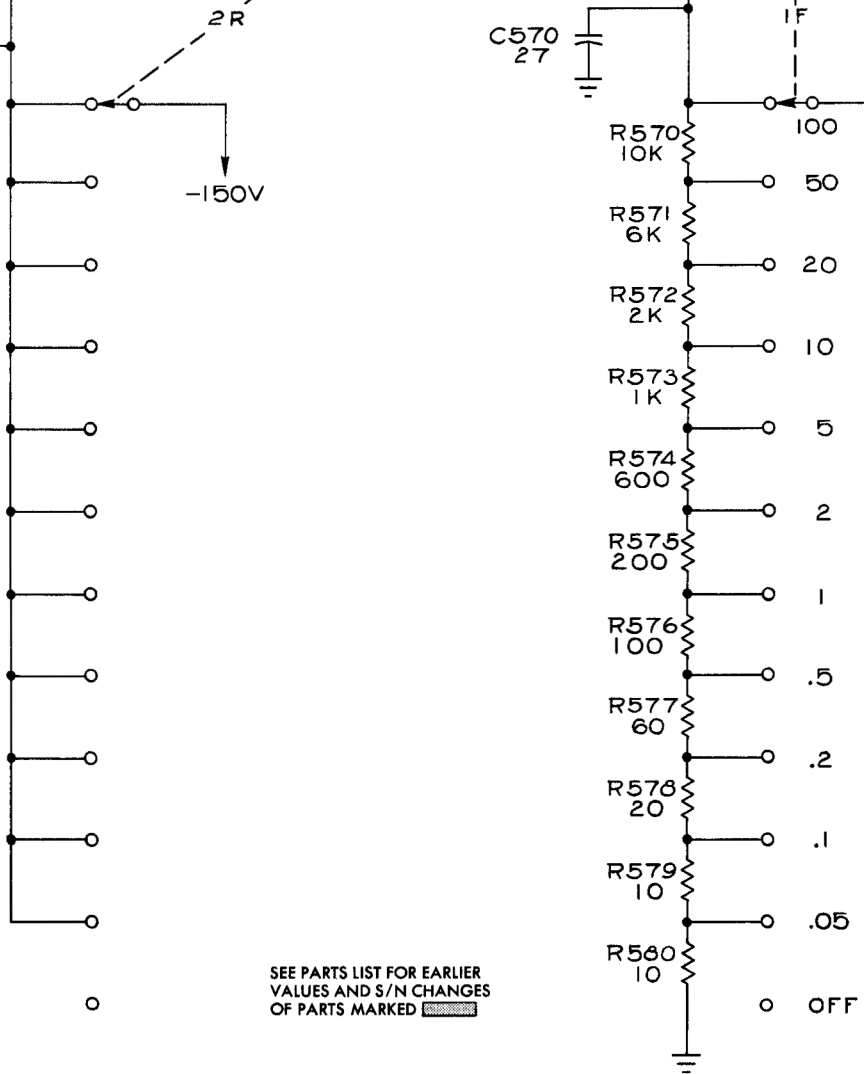

WAVEFORMS AND VOLTAGE READINGS
WERE OBTAINED WITH CONTROL SET AS FOLLOWS:
SQUARE-WAVE CALIBRATOR ON

5/5A AA CAL.

R.O.V.

5-4-61

SEE PARTS LIST FOR EARLIER
VALUES AND S/N CHANGES
OF PARTS MARKED

TYPE 515A OSCILLOSCOPE

AA₁

CALIBRATOR

PRIMARY & FAN CONNECTED FOR 234VAC OPERATION.

T600

V635
SERIES
TUBE

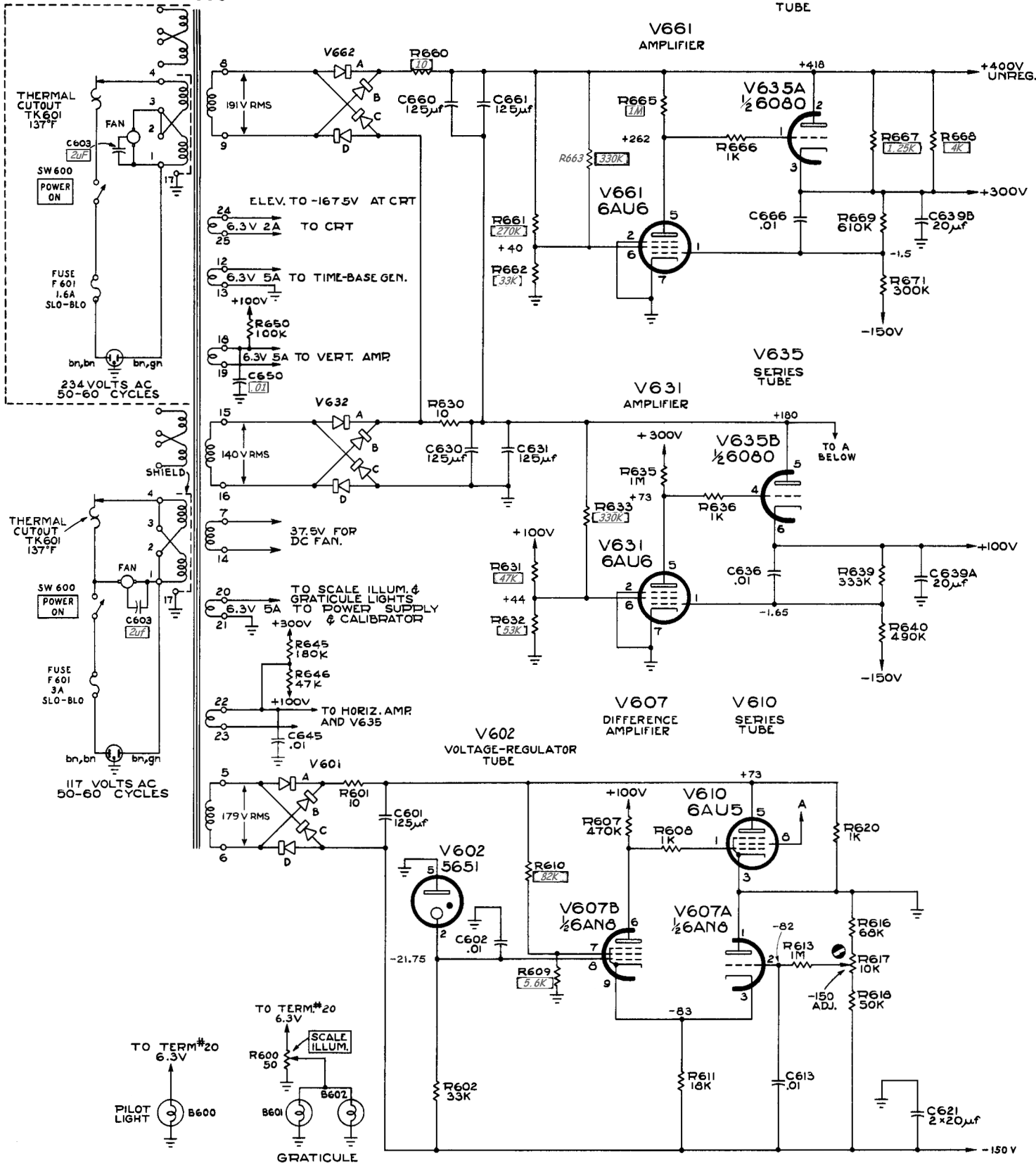

TYPE 515A OSCILLOSCOPE

VOLTAGE READINGS WERE OBTAINED WITH CONTROLS SET AS FOLLOWS:

VERTICAL INPUT SIGNAL	NONE
TRIGGER INPUT SIGNAL	NONE
LINE VOLTAGE	117VAC
STABILITY	CCW BUT NOT INTO PRESET

SEE ALSO IMPORTANT NOTE ON TIME-BASE TRIGGER DIAGRAM

SEE PARTS LIST FOR EARLIER VALUES AND S/N CHANGES OF PARTS MARKED

R.O.W.
5-4-61

LV POWER SUPPLY

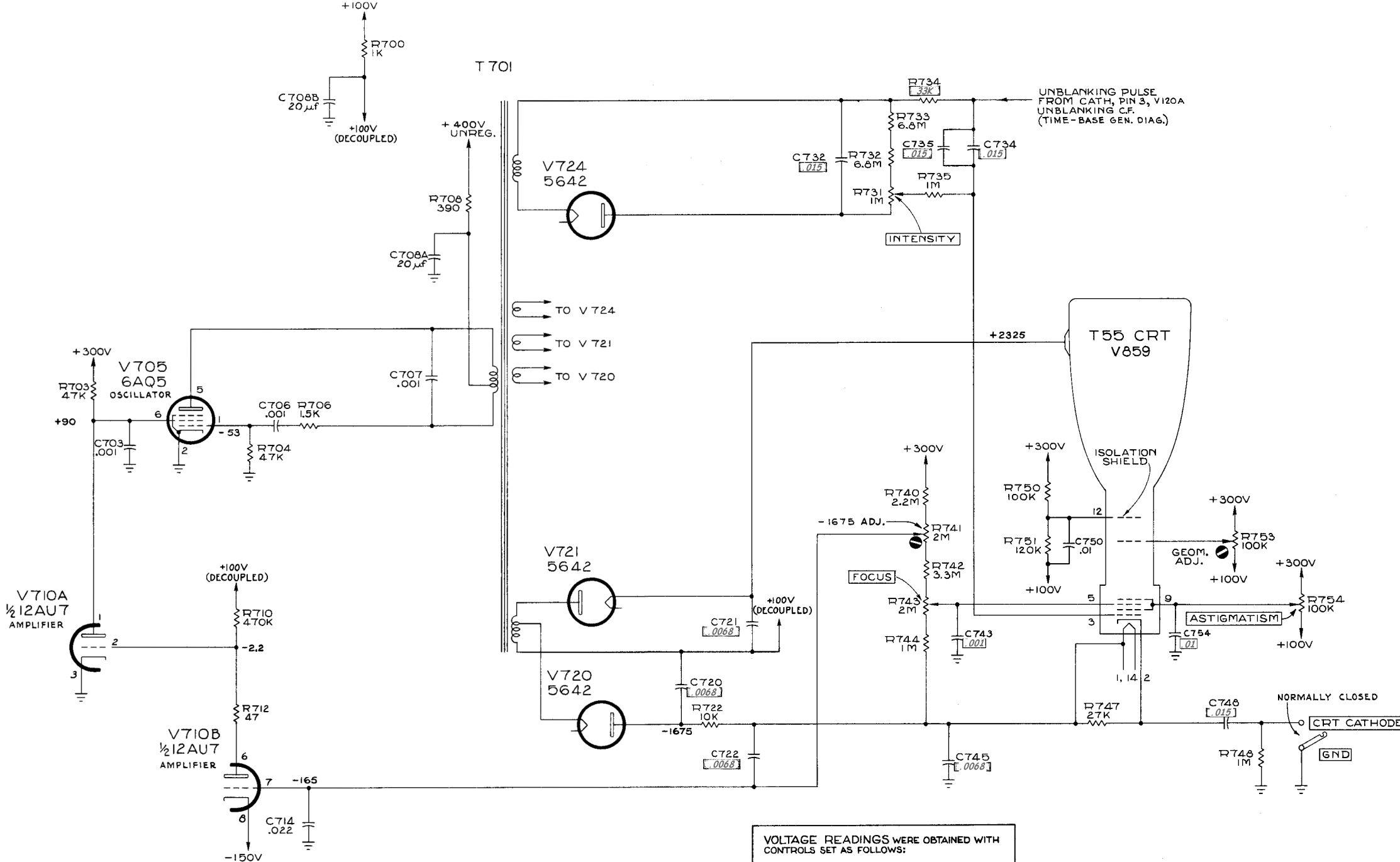

UNBLANKING PULSE FROM CATH, PIN 3, V120A UNBLANKING C.F. (TIME-BASE GEN. DIAG.)

VOLTAGE READINGS WERE OBTAINED WITH CONTROLS SET AS FOLLOWS:
 INTENSITY CCW
 SEE ALSO IMPORTANT NOTE ON TIME-BASE TRIGGER DIAGRAM

SEE PARTS LIST FOR EARLIER VALUES AND S/N CHANGES OF PARTS MARKED

R.O.W. 5-4-61

TYPE 515A OSCILLOSCOPE

<http://manoman.sqhill.com>

AB₁ 5/5A A4 CRT

CRT CIRCUIT